



ACO. The future of drainage.

The ACO Group – drainage and water treatment solutions



ACO. The future of drainage.

The ACO Group –

Drainage and water treatment solutions



ACO. The future of drainage.



The ACO system chain provides the drainage solutions for tomorrow's environmental conditions.

Increasingly extreme weather must be counteracted by more complex and sophisticated drainage concepts. ACO achieves this with intelligent system solutions which have a dual purpose: protecting people from water, and water from people. Every ACO product within the ACO system chain therefore safely controls the water as it passes along the chain to ensure that it can be ecologically and economically reused in a viable way.



collect

The surface water or the liquids being treated are collected from the surface as quickly and as completely as possible by the drainage system. This part of the ACO system chain guarantees protection, safety and comfort for the people, buildings and traffic routes in the immediate vicinity.



clean

The collected liquids are treated using integrated physical, chemical or biological processes that ensure they can be discharged into the public sewers – the minimum requirement. This part of the ACO system chain creates the conditions for recycling and sustainable use.



hold

Containers, barriers and valves ensure that the liquids stay within the drainage system where they can be properly controlled. This part of the ACO system chain enhances protection and safety for extreme situations: e.g. heavy rain, flooding or handling hazardous liquids.



release

Pumps, lifting plant and pipe systems transfer the collected, treated and controlled water into the downstream systems and processes. This part of the ACO system chain brings the collected, treated and controlled water to the interfaces for further treatment, re-use or release.



ACO system chain in action

ACO system solutions worldwide



- 8 — ACO products – High tech and craftsmanship
- 10 — The ACO Group

External Drainage

- 12 — Line drainage system
- 14 — Line drainage – all purpose system
- 16 — Line drainage – heavy duty
- 18 — Line drainage – monocast
- 20 — Line drainage – all-rounder
- 21 — Line drainage – large capacity
- 22 — Line drainage – roadside drainage
- 24 — Line drainage – architectually attractive solutions
- 28 — Line drainage – individual solutions in stainless steel
- 30 — Line drainage – domestic and economical solutions
- 30 — Line drainage – composite channels for professional solutions
- 34 — Point drainage

Access and Manhole Covers

- 36 — Access and Manhole covers – multiple and recessed
- 38 — Manhole covers – ductile iron

Landscaping

- 40 — ACO tree grate systems and grass grids
- 42 — Amphibian protection – ACO wildlife

ACO SPORT

- 44 — ACO SPORT drainage systems
- 46 — ACO SPORT construction elements and accessories

Roof Drainage

- 48 — Gravity roof drainage
- 49 — Siphonic roof drainage

ACO Pipe

- 50 — Stainless steel pipework system
- 51 — Galvanizes steel pipework system

Building Drainage

- 52 — Floor gullies
- 54 — Shower drainage – architectually attractive solution
- 56 — Stainless steel drainage

Separator Technology

- 58 — Grease separators and grease traps
- 60 — Petrol separators

Cellar Drainage / Backflow Preventers

- 62 — Backflow preventers
- 64 — Wastewater raising pumps and submersible pumps

Wastewater Treatment Technology

- 66 — ACO Maripur
- 67 — ACO Clara
- 68 — ACO references
- 70 — The ACO Group companies worldwide



High-tech and craftsmanship – our products

We manufacture our products world-wide at 26 modern environmentally-compatible production sites. ACO's high quality and productivity is based on the Group's world-wide expertise. In-depth research and development, and manufacturing competence built up over many years, create a solid platform for the processing of our most important materials: polymer concrete, stainless steel, plastic, ductile iron and reinforced concrete.



Polymer concrete: ACO is easily the world's biggest producer of polymer concrete. The first drainage products made of polymer concrete were launched at the end of the 1960's – they are still in use today and show no signs of damage. 13 of the ACO Group's sites produce the polymer concrete products which launched ACO on the road to success



Ductile iron: we have developed the traditional locations in Kaiserslautern and Aarbergen into high-tech production sites enjoying a high level of competitiveness in the international markets. The Michelbacher Hütte in Aarbergen is one of Germany's oldest foundries, with a history going back to 1652



Stainless steel: stainless steel sheets are processed throughout the ACO Group world-wide. High levels of investment ensure that our production plants are always state of the art, and produce innovative and competitive products



Concrete: we have produced reinforced concrete collectors and pump shafts for underground use for over thirty years. Together with our metal and plastic collectors, this makes us the market leader in Europe

Plastic: many ACO products benefit from the innovations and further developments generated by our plastics manufacturing activities. We process different kinds of plastic including

PVC, polycarbonate, polypropylene and polyethylene in three different processes: injection, rotomoulding and extrusion

Commitment to quality

Our modern, state of the art manufacturing plant produces high quality products which have been used in world wide projects.

- ISO 9001
- EN 1433
- EN 124
- KIWA – Third Party Control
- MPA – Material Testing Institute
- LGA – German Quality Institute
- LET – Quality Association for Drainage Technology
- DIBT – German Institute for Building Technology
- Member of the World Plumbing Council



Quality controls throughout the production process guarantee unchanging standards of high quality you can trust. We use an integrated quality assurance system underpinned by state-of-the-art computer backed testing equipment to monitor the required standards



The headquarter of the ACO Group in Rendsburg, Germany



ACO worldwide

We are present with independent companies in over 40 countries on all continents. We have our own production sites in 14 countries including Australia, the USA and China. At the same time as respecting national cultural differences, the focus of our marketing activities is always the ACO brand with its excellent image, high quality standards and unique competence. ACO Group is the worldwide leader in the manufacture and supply of drainage technology for external and internal applications. With more than 50 years of valuable experience ACO stands for professional drainage, efficient cleaning, and the controlled discharge or reuse of water.



ACO United Kingdom, Shefford



ACO Austria, Baden

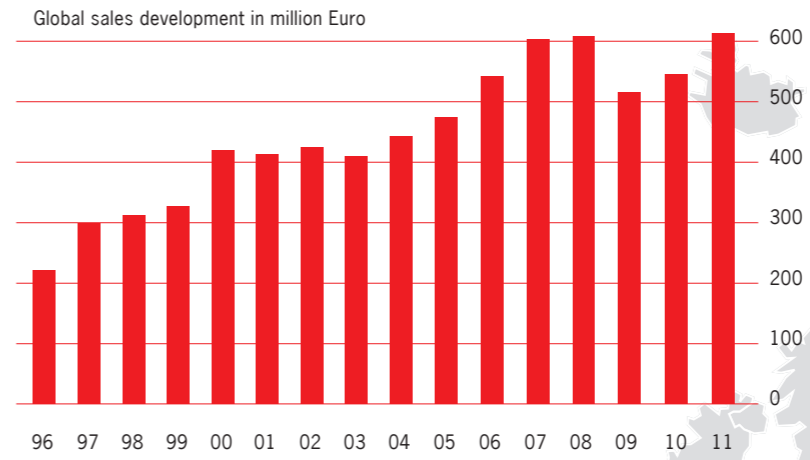

- ACO group at a glance:**
- 3700 staff in more than 40 countries (Europe, America, Asia, Australia)
 - 26 production sites in 14 countries
 - Turnover more than Euro 600 million

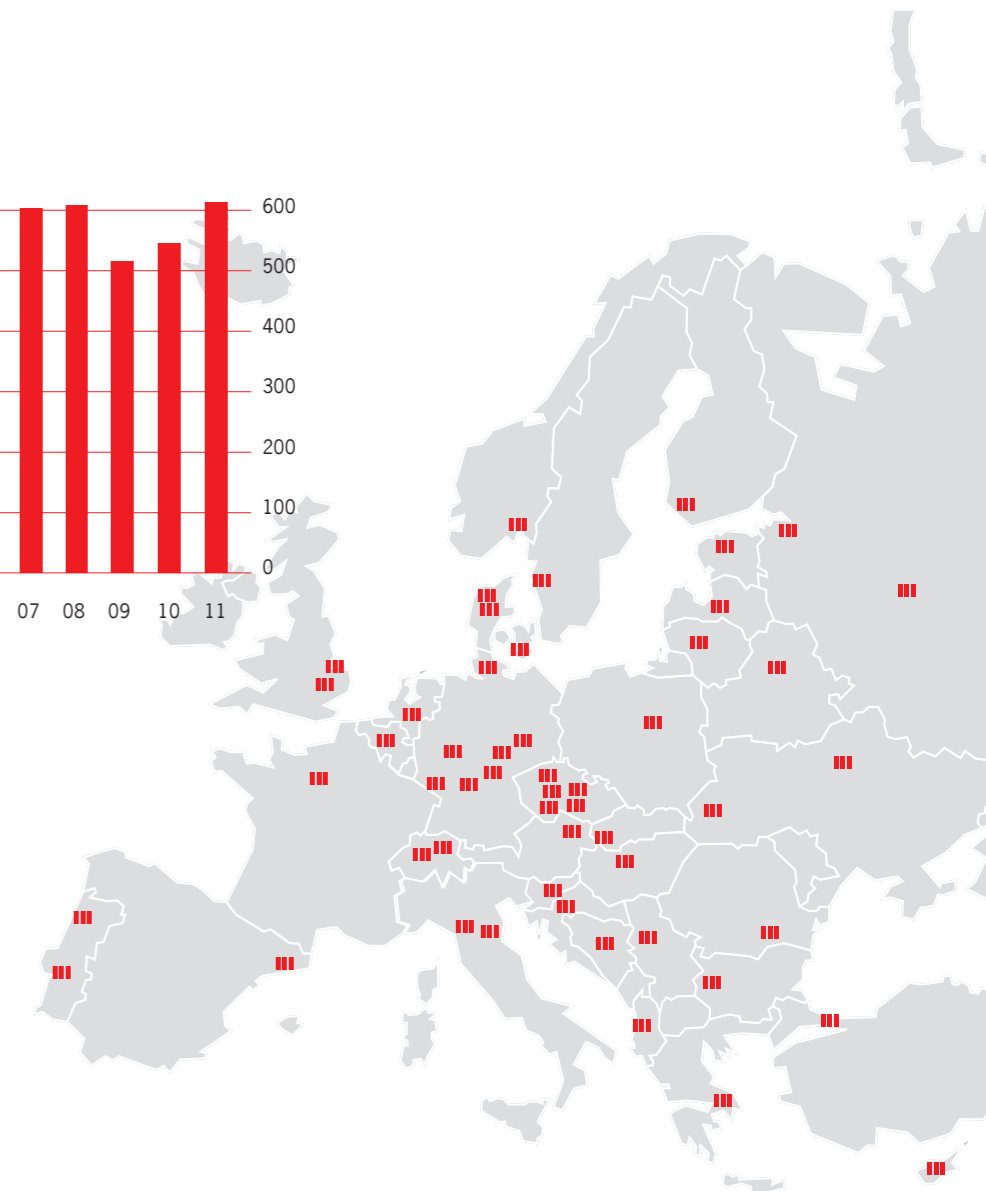

ACO Academy, Germany, Rendsburg



ACO USA, Casa Grande



ACO Czech Republic, Přebyslav



ACO China, Shanghai



ACO Switzerland, Netstal

ACO DRAIN® line drainage system— freedom of design through product versatility

The ACO DRAIN® programme is a genuine modular system: individual, personalised solutions can be combined from a range of channels, gratings and system accessories such as sump boxes – a system which will convince you in terms of technology and economy. Take for example the ACO DRAIN® Multiline® line drainage system.

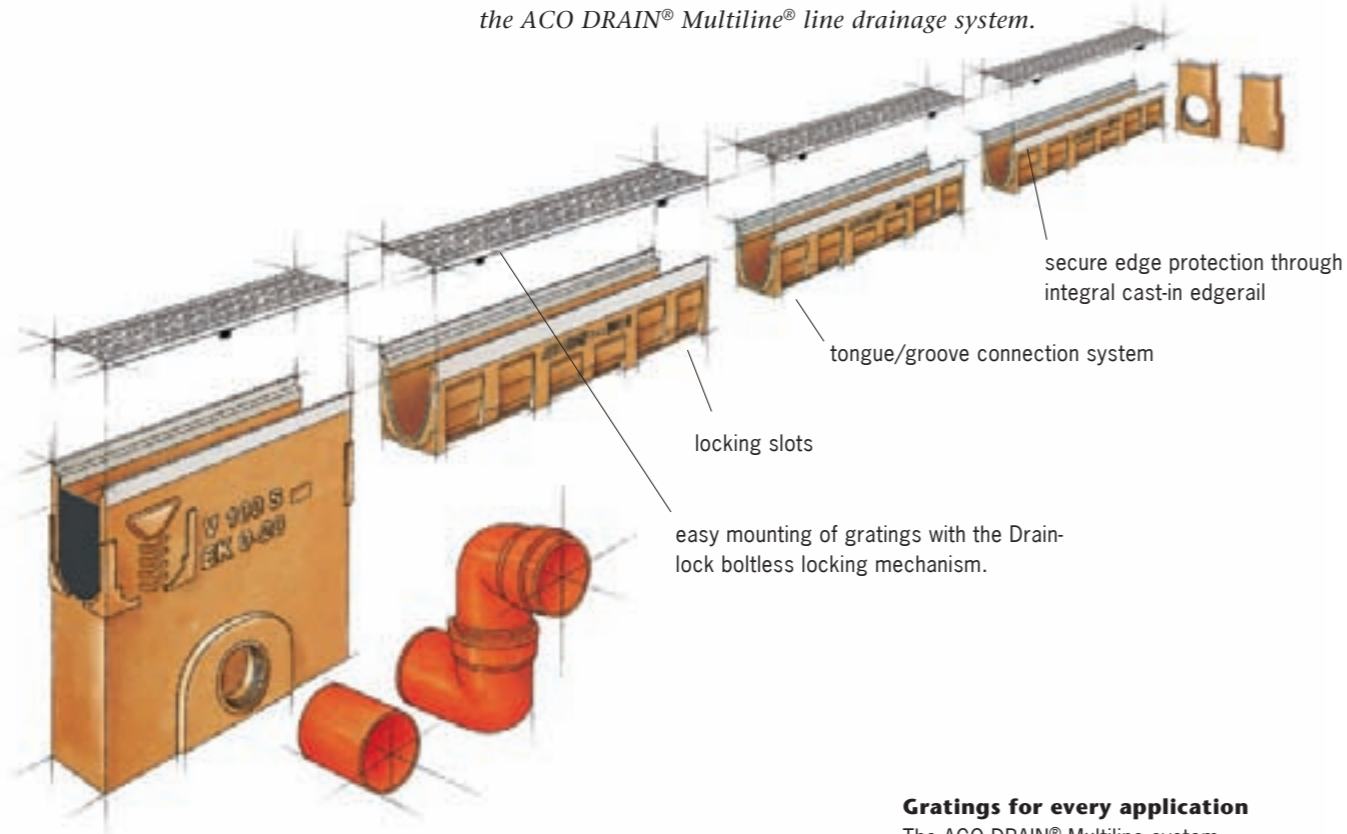

the sump box can be cut to allow any depth of channel connection.



Traffic-safe locking of all gratings using the Drainlock locking mechanism

Gratings for every application

The ACO DRAIN® Multiline system solution has a simple range of different gratings suitable for most architectural requirements in terms of aesthetics, functionality and strength. The gratings can be combined as required independent of the channel body and are suitable for all load classes from A 15 to E 600.

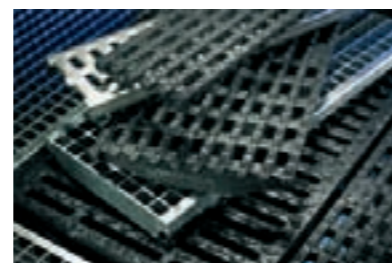

ACO DRAIN® grating range: Clear, flexible, creative

ACO DRAIN® line drainage system:

Protecting buildings, designing paved surfaces

Traditionally, point or cast-in-place drainage has been used to provide surface water removal for all types of applications. On face value they often appear to be the cheapest methods around. Certainly material costs can be low. However, when installation, labour and site preparation costs are taken into calculation, significant savings can be made by using precast channel drainage systems.

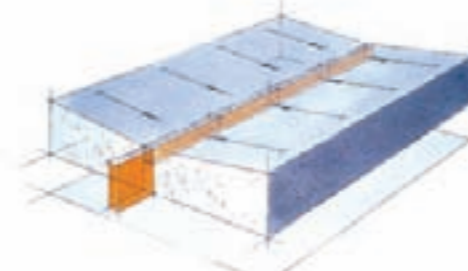

ACO is the world leader in the design and manufacture of polymer concrete surface drainage systems. ACO DRAIN® surface drainage systems are designed to carry surface water and other liquids efficiently from a paved or hard-surface area to the underground drainage system.

What is polymer concrete?

Polymer concrete is a versatile highly durable material. It is a mixture of mineral aggregates and resins, which forms a lightweight, corrosion resistant material ideally suited to channel drainage.

■ strength

Polymer concrete has approximately four times the compressive strength of conventional concrete at the half the weight of an equivalent section

■ lightweight for easy installation

ACO products are lighter than equivalent conventional concrete channels, making installation and handling easier. Most components weigh less than 40 kg and can be carried easily

■ durability and corrosion resistance

Polymer concrete is inherently resistant to a wide range of acids, alkalis, sulphates and detergents. It has an extremely low water absorption rate and is thus unaffected by repeated freeze-thaw cycles and road salts

■ hydraulic efficiency

ACO DRAIN® channels are precision moulded with a built-in slope and an ultra smooth finish which encourages efficient hydraulic flow. (Mannings roughness coefficient 0.011). This ensures greater discharge rates than equivalent sized cast-in-place concrete drains



DIN EN 1433 table of load classification*

	class A 15 ¹⁾	traffic areas used exclusively by pedestrians and cyclists, and similar areas such as green spaces
	class B 125 ¹⁾	pavements, pedestrian areas and similar surfaces, car parks and parking decks
	class C 250 ¹⁾	kerb areas of streets and pavements
	class D 400 ¹⁾	road traffic lanes, also pedestrian precincts, car parks and similar paved traffic areas (e.g. freeway parking lots)
	class E 600 ¹⁾	non-public traffic areas subject to particularly high wheel loads, e.g. industrial traffic lanes
	class F 900 ¹⁾	special areas e.g. aircraft handling areas at civil and military airports

* traffic area classification for drainage channels, construction and testing regulations, conformity labelling and assessment.

¹⁾ Test force in kN

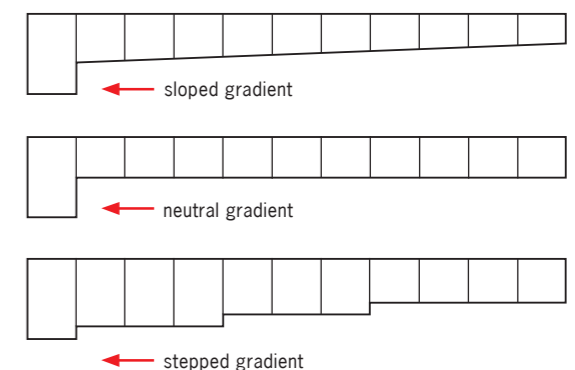

ACO DRAIN® trench drainage systems are suitable for all types of gradients from sloped to neutral and also allow the combination of different gradient types.

ACO line drainage – all purpose system

ACO DRAIN® Multiline V 100 – 500

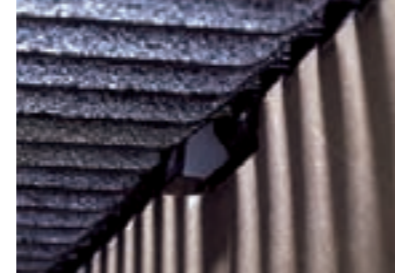

The new boltless Drainlock snap-on locking mechanism has anti-shunt lugs to prevent longitudinal movement, and enables the simple fixing and removal of grates

The technical trick is the V-profile.

ACO DRAIN® Multiline sets new standards with its channel cross-section. The range is also based on a new idea: a universal channel body can be used for every nominal width and type of edge-rail for load classes A 15 to E 600.

Typical applications

- car parks
- railway platforms
- architectural surfaces
- pedestrian zones
- landscaping
- industrial surfaces



The channel system ACO DRAIN® Multiline:
 – nominal widths: 100, 150, 200, 300, 400 and 500
 – ductile iron, stainless steel and galvanized steel edge-rails
 – for load classes A 15, B 125, C 250, D 400, E 600 EN 1433

Line drainage of the future

Technical superiority

The heart of the innovation is the V-profile. This new channel profile improves the drainage capacity and enhances the self-cleaning effect. The new side wall structure and the intelligent distribution of materials considerably increases the load-bearing strength and the overall stability. This results in simpler installation even though the system has an extremely high load-bearing capacity. The ACO DRAIN® Multiline universal system is available with all gradient types which can also be freely combined with one another.



The integrated edge-rails firmly cast-in with the polymer-concrete channel body provide reliable edge protection

Watertight

The complete tightness of the channel body right up to the top of the edge rails, and the very smooth surface, increase drainage volumes during extreme storms. The ACO safety rebate ensures that the channel body units are connected to one another with a 100 % watertight seal. The new cast-in lip labyrinth seal ensures that the drainage system can be connected with a watertight seal to the drainage pipe system. ACO DRAIN® Multiline easily complies with DIN EN 1433 specifications with a very large safety margin.



Complete watertightness right up to the top means 100% compliance with the standards

Creative and versatile

The ACO DRAIN® Multiline V 100 – 500 system solutions have a clearly defined programme of gratings suitable for most architectural requirements in terms of aesthetics, functionality and load bearing strength. The different gratings can be freely combined independent of the channel bodies and are available for all load classes from A 15 to E 600.

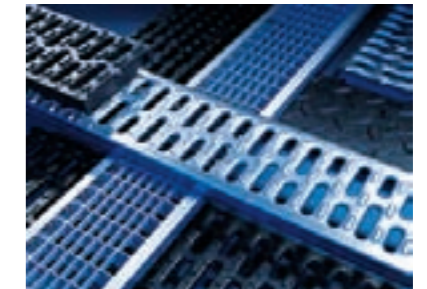

The ACO DRAIN® Multiline V 100 grate range: clear, flexible, creative

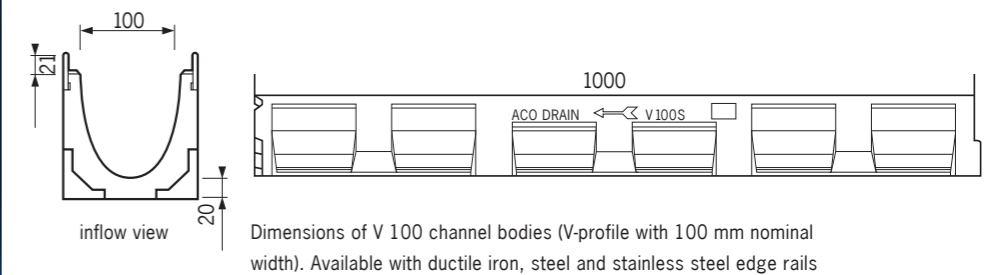

ACO line drainage – heavy duty
ACO DRAIN® S 100 K to S 300 K



ACO DRAIN® S 100 K to S 300 K systems are ACO's heavy duty solution – suitable for all load classes from A 15 to F 900 to EN 1433.



Typical applications

- line drainage on motorways
- storage and filling yards
- industrial surfaces
- airports
- container transhipment surfaces
- petrol stations

Stability under the highest loads

Load resistance

The high strength of this heavy duty channel system is based on many details:

- reinforcing ribs increase side wall strength and optimise load distribution
- special anchoring feet provide perfect stability in the concrete surround
- integrated anti-shunt lugs to prevent longitudinal grating movement, and low centre of gravity provides safety even during installation
- an abutting edge rail for paviers of 10 cm height avoids unnecessary seams
- smooth lateral walls are free of any protrusions, permitting easy abutment of surface coverings such as paviers, asphalt or concrete
- Powerlock boltless locking with stainless steel locking springs, replaces bolts for easier assembly and maintenance

Award winning design

This product was awarded a German product design (recognition) award for its excellent combination of form and function. A great design with many beneficial features:

- high load resistance
- high inflow profile
- longitudinal bars preventing water by-pass
- powerlock boltless locking
- anti-shunt lugs to prevent longitudinal grate movement
- high quality coating to prevent corrosion
- grate installation independent of channel direction



In this example, the grates and edge rails were coated grey to match the colour of the paving stones



ACO DRAIN® SK heavy duty channels are also available with bolted grates



Powerlock boltless locking mechanism with stainless steel locking spring



S 100 K channel. Appearance and functionality optimised by a new grating design

System overview

system	length	width	height
S 100 K	50/100 cm	16 cm	10,0 to 26,5 cm
S 150 K	50/100 cm	21 cm	22,0/27,0/32,0 cm
S 200 K	50/100 cm	26 cm	29,0/34,0/39,0 cm
S 300 K	50/100 cm	36 cm	40,0 cm

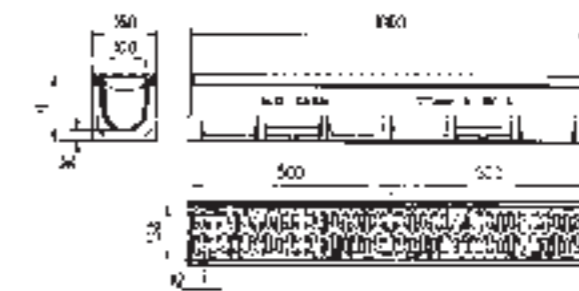

Dimensions of S 100 K channel body, 1.0 m

ACO line drainage – monocast ACO DRAIN® Monoblock



ACO DRAIN® Monoblock is a one-piece polymer concrete drainage system developed as a solution for a range of surface draining applications from load classes C 250 to F 900.



ACO DRAIN® Monoblock system in:
– natural and anthracite black
– nominal widths 100, 200 and 300
– load classes C 250 to F 900

■ Polymer concrete makes Monoblock:

- light
- age-resistant
- high-strength
- rust-free
- frost, de-icing salt and chemical resistant

Safety, stability and high functionality – thanks to monocast construction

The unique monocast construction guarantees extremely high levels of safety and stability in all transport surface drainage applications. The high inflow cross section and the V-profile ensure rapid surface drainage. A simple modular principle with only six system elements quickly and easily provides solutions for a whole range of applications.

Easy installation and maintenance

ACO DRAIN® Monoblock is a winner thanks to the simple and minimal use of system components. Bracing elements are not required. The integrated safety rebate ensures that there are watertight seals between each unit as required by EN 1433 specifications. The channel is simply cleaned by flushing. The 0.5 m element with the removable grating gives free access to the whole drainage trench.



ACO DRAIN® Monoblock RD 200 V



ACO DRAIN® Monoblock RD 100 – easy to install without lifting gear.

Typical applications

- line drainage on motorways
- line drainage in inner-city areas
- drainage across traffic lanes
- industrial surfaces
- airports
- container transshipment areas
- motor racing tracks



ACO line drainage – all-rounder
ACO DRAIN® Powerdrain



The ACO DRAIN® Powerdrain system is a real all-rounder. The product line boasts a convincing new scale of nominal widths, universal stability, functionality and design freedom, not to mention innovative noise damping.

Slim, quiet and extremely efficient

Slim solutions are not just good looking: the combination of crucial product properties make the ACO Powerdrain a real professional all-round solution in polymer concrete. Its compelling features include unusually good hydraulic specifications, extremely high safety, and outstanding stability right up to the toughest heavy duty class F. All of these product benefits are founded on four main properties:

- reduced nominal widths
- innovative V-channel profile
- rugged sidewall construction
- integrated damping



slim: V-profile for high hydraulic performance



quiet: the special elastomer damping means permanent noise damping



efficient: the boltless lock and tried-and-tested installation aids boost safety and efficiency at the construction site



ACO DRAIN® Powerdrain V 75 P, 20.0/0.0 and V 125 P, 20.0/0.0

ACO line drainage – large capacity
ACO Qmax – an advanced drainage system



The ACO Qmax line drainage system was developed to satisfy demands for economical high-capacity drainage systems for large catchment areas. ACO Qmax has passed independent load tests to class F 900 in accordance with EN 1433.

Typical applications

- airport surfaces
- distribution centres
- highways
- car parks



Qmax flow regulator

The ACO Qmax system features the first genuine flow management and attenuation control as an integrated part of line drainage solutions. ACO Q-Brake has no loose or moving parts, is compact, and takes up no additional volume being situated within the channel. Its performance is completely laboratory certified.



ACO Qmax is available in different sizes and lengths providing an effective and economical drainage solution for the application requirement

Qmax features

ACO Qmax was designed to handle high hydraulic capacities, enable minimum installation times, and be lightweight and yet rigid enough to withstand the rigours of typical construction site handling practice. Manufactured from tough, chemically resistant medium density polyethylene (MDPE), ACO Qmax is light, easy to handle and quick to install. Connecting to pipes is also made easy with the availability of a special side inlet unit.

The ACO Qmax system is a patented design currently available in four sizes for effective and economical drainage of a range of catchment sizes: ACO Qmax 225 can carry flows of around 25 l/s even when laid level (depending on channel length etc.). The largest ACO Qmax 900 can carry flows of around 300 l/s when laid level and considerably more when laid with a gradient.



ACO line drainage – Roadside drainage with ACO DRAIN® KerbDrain

A new generation: kerbs with integrated line drainage.

KerbDrain stands for the brilliant concept of combining kerbstones with drains, to create one compact unit.



ACO DRAIN® KerbDrain for parking areas

Two functions – one solution

Versatile

ACO DRAIN® KerbDrain is an extremely versatile system that can be used wherever drainage is required for paved surfaces, such as car parks, bus stops and traffic calming zones.

Roundabout application

ACO DRAIN® KerbDrain is ideal for draining roundabouts. It makes it possible to optimally drain the traffic lanes in roundabouts towards the inside or the outside, up to load class D 400. In addition, KerbDrain can be extended to optimally connect up to existing drainage systems.

ACO DRAIN® KerbDrain is available in three heights: 480 mm, 305 mm and 255 mm.



ACO DRAIN® KerbDrain showing heights 480 mm and 305 mm



ACO DRAIN® KerbDrain with cambered kerbstones for driveways



Kerbstone and drain in one, ACO DRAIN® KerbDrain

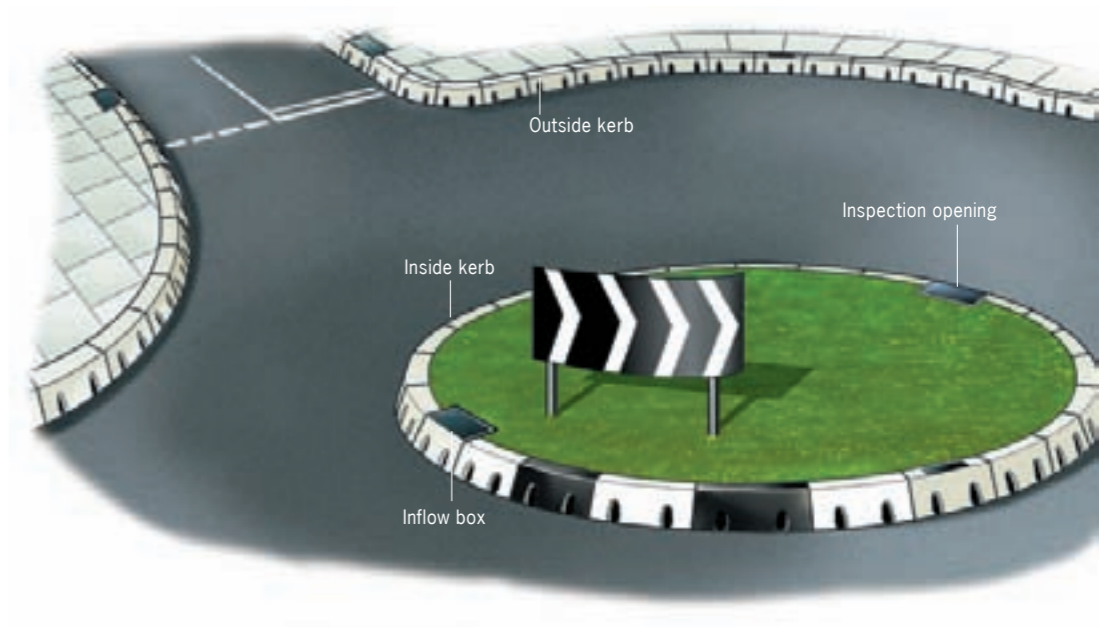

External Drainage

ACO line drainage – architecturally attractive solutions



Discreet and inconspicuous, the V 100 S and V 150 S ACO DRAIN® Multiline slotted channel systems open up a new approach to designing open spaces. A narrow slot replaces the grating and forms a clean, unobtrusive line in the paving.



In harmony with all surface coverings



Shanghai central station. The slot can be offset in harmony with the architectural design of the surface

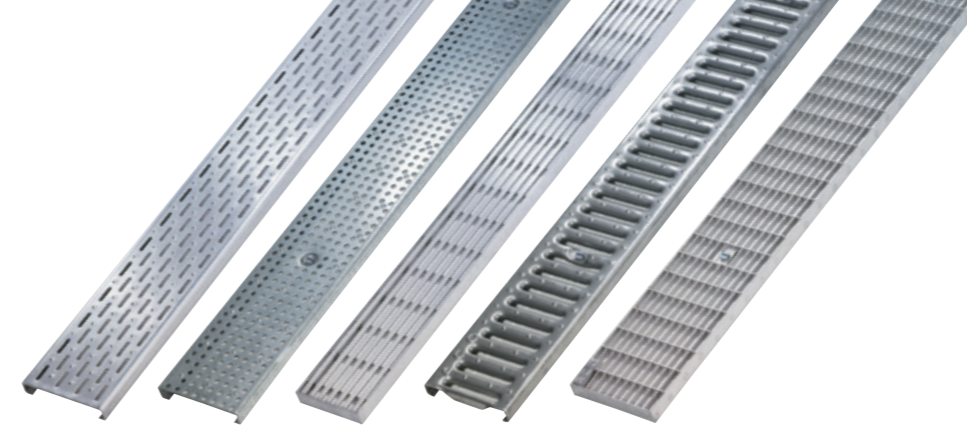

ACO Profiline channel unit, adjustable height



ACO Profiline is a complete channel drainage system for draining vertical façades, as well as terraces, balconies, flat roofs, green roofs and roof gardens – the perfect solution for sophisticated function and design projects.

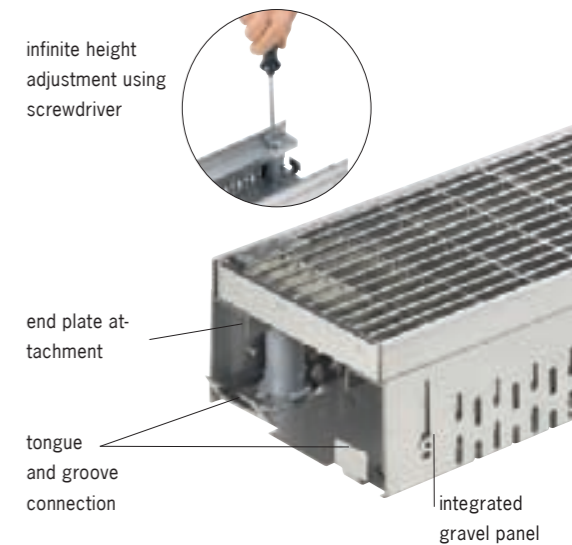

ACO DRAIN® slotted channel system Multiline

Designing with clear lines

The system is also ideal for transitions between two different surfaces. The slotted frame consisting of galvanised steel or stainless steel is compatible with all standard paviors or stone slabs and joins the two surfaces almost seamlessly.

This system is superb for the drainage of façades and optically sophisticated surfaces.

Functionality and maintenance

Simple cleaning and maintenance with low or high pressure washers. Access openings simplify maintenance of the subsurface polymer concrete or plastic channels with their excellent hydraulic performance.

Typical applications

- piazzas
- paths
- facades

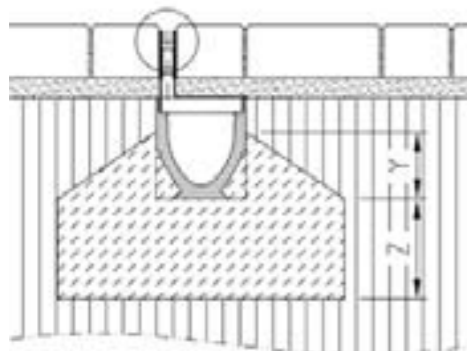

Installation example



Slotted channel V 100 S, 1,0 m



Slotted channel XtraDrain, Plastic channel, 1,0 m

ACO Profiline

Planning and design with no limitations

The ACO Profiline channel system is a reliable professional solution for the drainage of façades, terraces and balconies. It is available in fixed heights of 5.0 and 7.5 cm, as well as in continuously adjustable versions between 6 to 16.5 cm. Customised versions can also be supplied upon request.

The advantages for planners and designers: ACO Profiline enables the connection height to building seals to be reduced from 15 cm to 5 cm. The channel system works on two levels: it drains the water from the surface as well as water from the underlying drainage layer. Water flowing down façades is also reliably collected and removed. Backflow reservoirs prevent the build-up of water puddles during sudden downpours. ACO Profiline is available in galvanised steel and stainless steel versions and therefore perfectly harmonises with visually sophisticated settings.

Installation example:

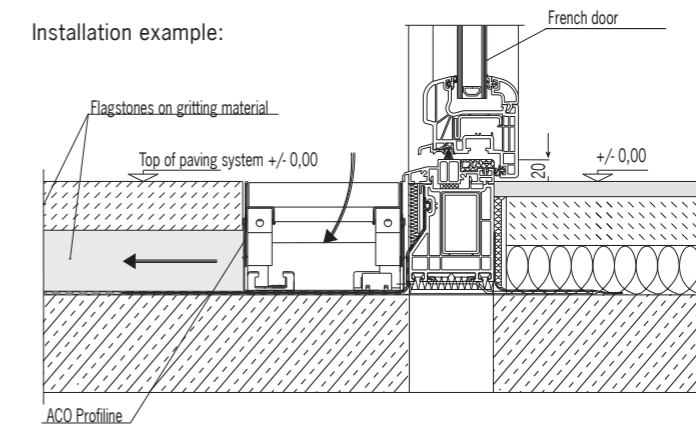

Typical applications

- façades
- terraces
- balconies
- flat roofs
- green roofs
- roof gardens



ACO line drainage – architecturally attractive solutions

ACO DRAIN® Lightline, Sideline, Lightpoint and ACO Eyeleds



Lighting and drainage – ACO DRAIN® Sideline

ACO DRAIN® Lightline, ACO DRAIN® Sideline, ACO DRAIN® Lightpoint and ACO Eyeleds provide highlights in architectural and open space designs. Public areas, entrance halls and paths become more attractive and more functionally designed. Technical perfection and individual design flexibility provide planners and builders with a wealth of versatile applications.

Innovation award
Architecture and Technology.

Innovationspreis
Architektur und Technik

Launched with huge success at the 2004 light+building exhibition, INSTA Elektro GmbH presented the new ACO DRAIN® Lightline, which was nominated for the Architecture and Technology award and presented with a special recognition award in the lighting category

Typical applications

- piazzas
- paths
- entrance halls

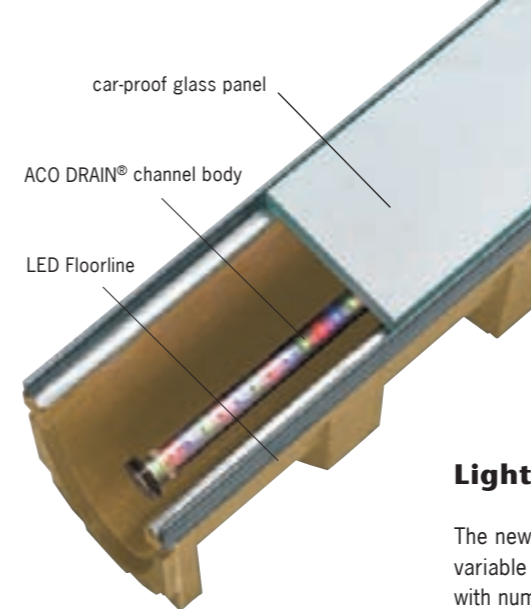

Trend-setting lighting and aesthetics in perfect harmony: ACO DRAIN® Lightline for customised use. Car-proof

Lighting instead of drainage – ACO DRAIN® Lightline

The new ACO DRAIN® Lightline with its variable colour effects provides planners with numerous application possibilities in the colour design of open spaces. ACO DRAIN® Multiline channels in combination with LED Floorline and car-proof non-slip glass technology merge perfectly to create an architectural lighting design element.

LED Floorline is available in the standard colours white, blue and green. Other technologies are available for lighting with customised colours and for creating colour effects and sequences. The ACO DRAIN® Lightline cover panel consists of a safety-glass cover which is non-slip and car-proof, and securely enclosed in a stainless steel frame.

Lighting and drainage –

ACO DRAIN® Lightpoint, Sideline and Eyeleds

ACO DRAIN® Lightpoint

The LED Lightpoint is available in various colours (e.g. white, blue). 18 lightpoints can be run from a modular plug-in power supply unit. The lightpoints are interconnected by a simple plug arrangement. The LED Lightpoint is simply inserted into the special opening in the ductile iron grate and fixed into place to retain the drainage function of the grate and the channel.

ACO DRAIN® Sideline

For some years now, drainage channels disguised as narrow slots have been upgrading squares and paths, as well as gardens and parks, with their clean lines. Slotted drainage channels have now become even more attractive with the addition of another design dimension: the new ACO Sideline stands out with its sophisticated symbiosis of drainage and LED technology. The enhanced feeling of safety is an important plus point in addition to the highly effective design character.

ACO Eyeleds

Light and expressive – the LED points are installed in a high-strength composite grating. The LED technology creates a powerful lighting effect even though the lights are only 2 cm in diameter. Garage drives, squares, footpaths, pedestrian zones, access routes, boulevards and railway platforms can all be attractively highlighted by ACO Eyeleds. In addition to decorative effects ACO Eyeleds can also improve overall safety in busy areas.



The lightpoint is another way of highlighting the line drainage system. Vehicle-proof to class D 400

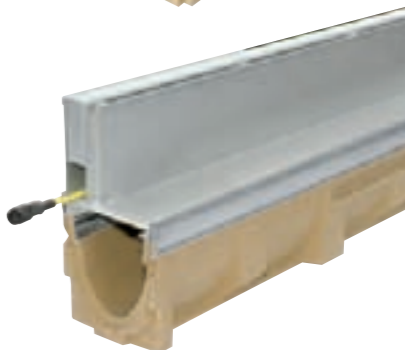
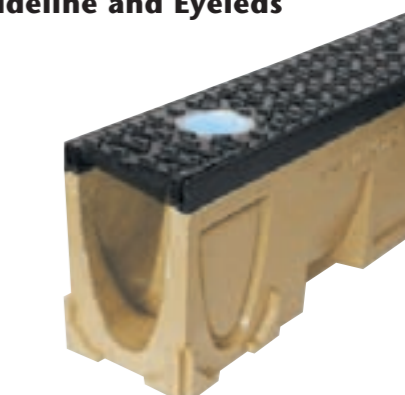

ACO Eyeleds can be combined with either ACO's polymer concrete Multiline system, or plastic channels in the class B 125

ACO individual solutions in stainless steel – accents for good architecture



ACO channel grates and covers in stainless steel support customised design down to the finest detail

In addition to perfect function, another key feature of ACO brand policy is the high aesthetic quality of its products. This gives rise to added value which is appreciated just as much by our customers as the professionals because many ACO products have already won awards for their innovative design.

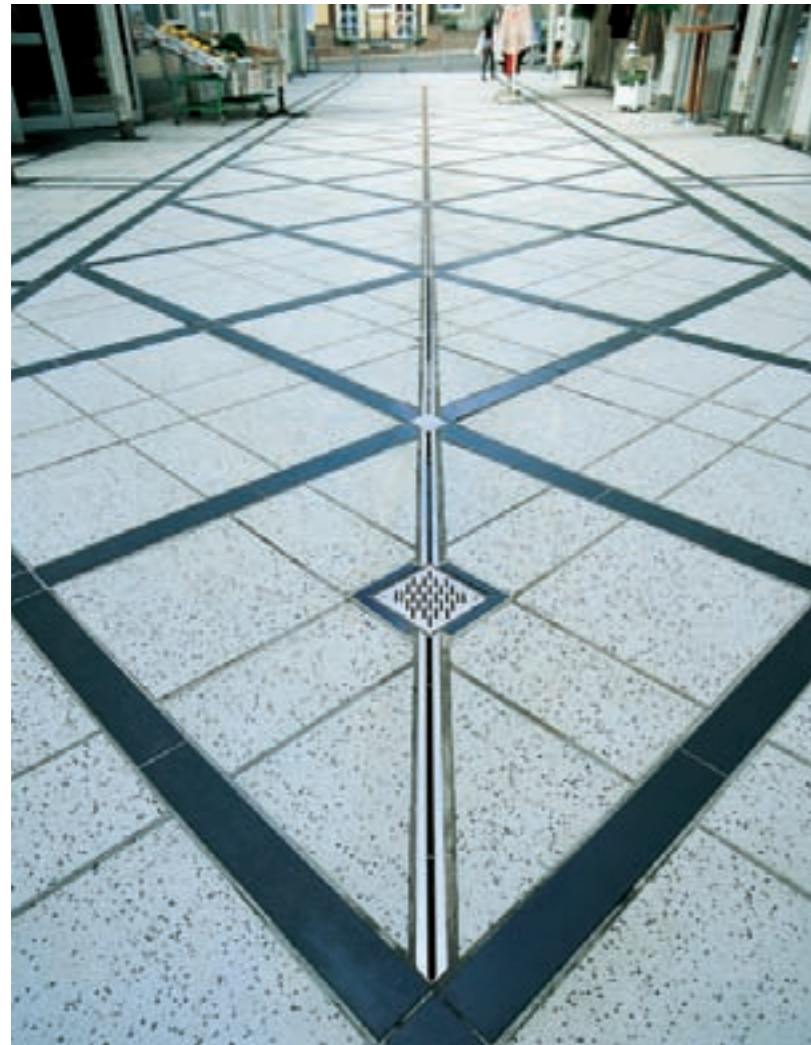

- Typical applications**
- piazzas
 - façades
 - pedestrian areas
 - arcades and passages

Sophisticated optical solutions for passages and arcades

Customised for sophisticated planning



Channel drains in stainless steel combined with a wide range of different grating types, provide design accents as well as safely draining away water from façades and paved surfaces



Channel drain variations

Form and function

Chrome-nickel steel combines durability and beauty: form and function in perfect harmony. All of the components are durable, tough, non-deformable, corrosion-resistant and long-lived.

Design

The broad spectrum of finishes and shapes gives you complete freedom with your designs. Even unusual concepts can be easily realised using stainless steel. Customers' individual project designs can be supported by our expert team with tailor-made services for your specific project with full proposal information, CAD layout drawings and assembly instructions.



Slotted channels for abutting paving stones are harmoniously integrated into the overall floor surface. These can be custom manufactured, individually with or without an integrated gradient, in straight, radial or polygonal designs



Compact heavy-duty construction in stainless steel

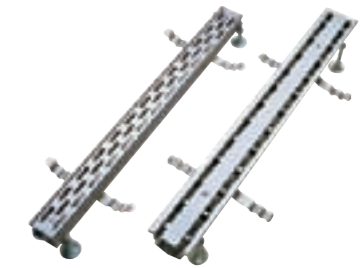

Compact channels



Slotted channels

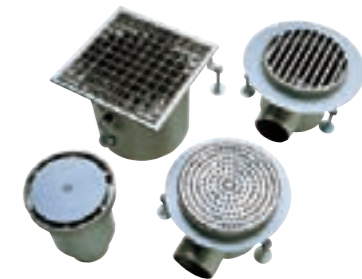

Customised outdoor gullies

ACO plastic channels – domestic and economical solutions



The new ACO Hexdrain plastic channel is ACO's answer to the demand for inexpensive but effective surface drainage systems. The Hexdrain channel system was specially developed for the safe and attractive drainage of patios, drives, and other paved surfaces.

Typical applications

- garages
- patios
- drives
- pedestrian areas

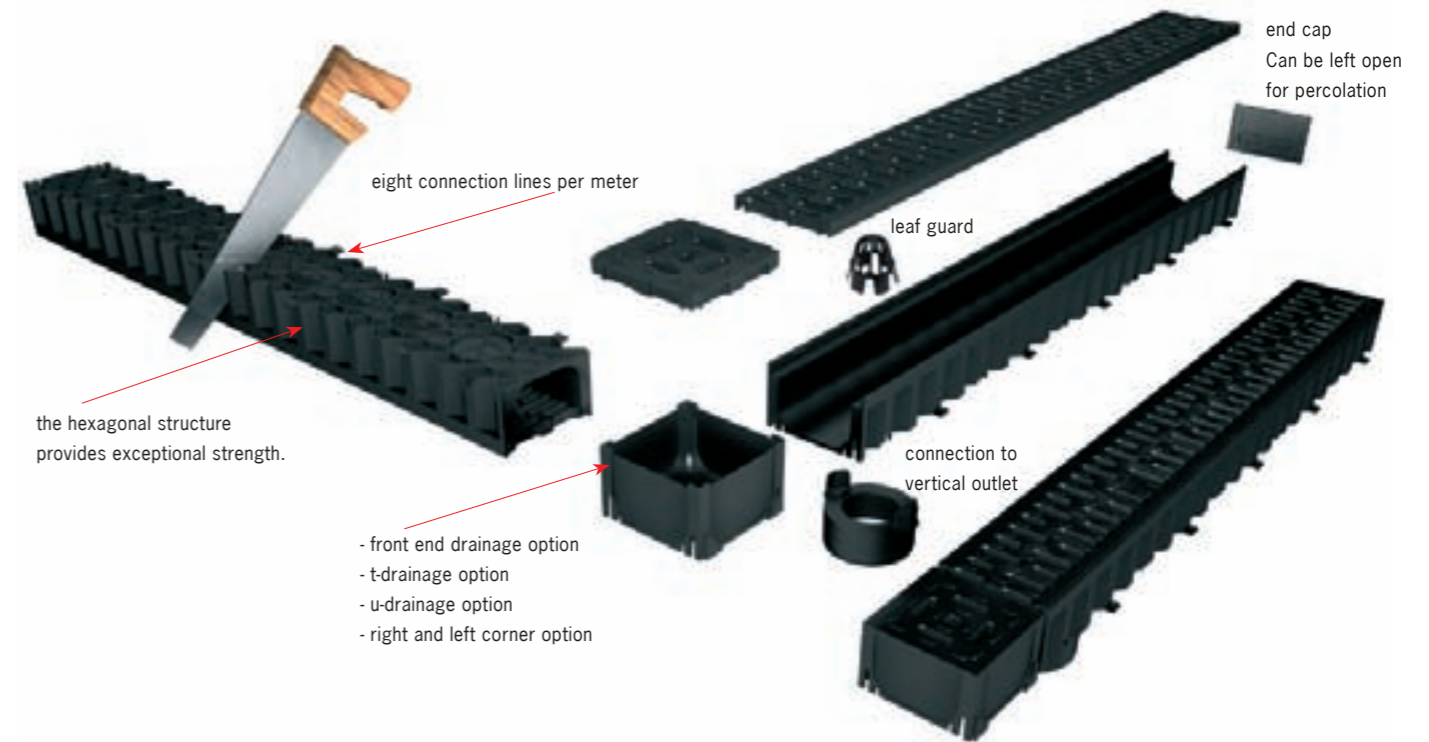

Plastic – the alternative to polymer concrete

These channels are – lightweight – rugged – unbreakable thanks to the use of recyclable plastic and an innovative production method.

The honeycomb shape of the sidewalls makes the channels exceptionally tough. So strong, they don't need to be bedded in concrete. The surface covering can directly abut the channels for a clean finish.



1 m grating in metallic grey and black. Also available in galvanised steel (on top)

Benefits

- available in metallic grey or black
- easy-to-install flexible system
- simple to cut with a saw
- multi-option corner unit
- installation instructions on the product itself
- perforated end cap
- car-proof, class A 15
- EN 1433



Slotted top for ACO Hexaline – More stylish looks for your outdoor areas

The ACO Hexaline slotted top replaces the 12 cm wide drainage channel grating with a less than 2 cm wide slot which fits elegantly into the overall look – at the end of your drive, on your patio, or alongside a garage.

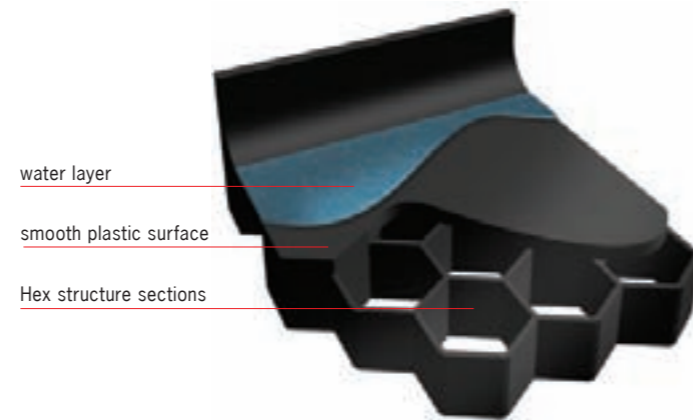
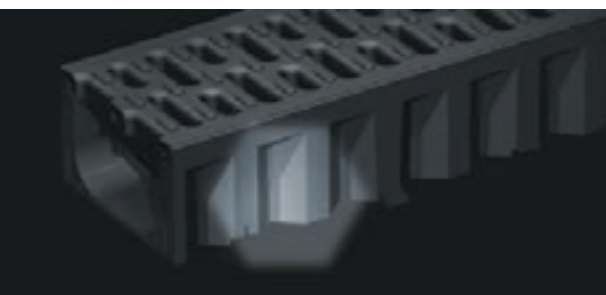

the hexagonal structure provides exceptional strength and rigidity whilst keeping weight to a minimum. The hexagonal shapes are also utilised to provide simple positive connections for accessories

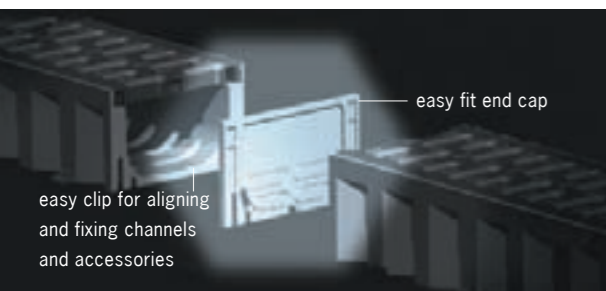

ACO XtraDrain composite channels for professional solutions



Easy handling right down to the last detail, combined with the highest quality: the new ACO composite drainage channel. Designed with premium composite and capable of withstanding loads to class D 400. A great new drainage channel, especially for applications involving the design of open spaces, and gardening and landscaping – which all benefit from this technically perfect and aesthetic solution for line drainage.

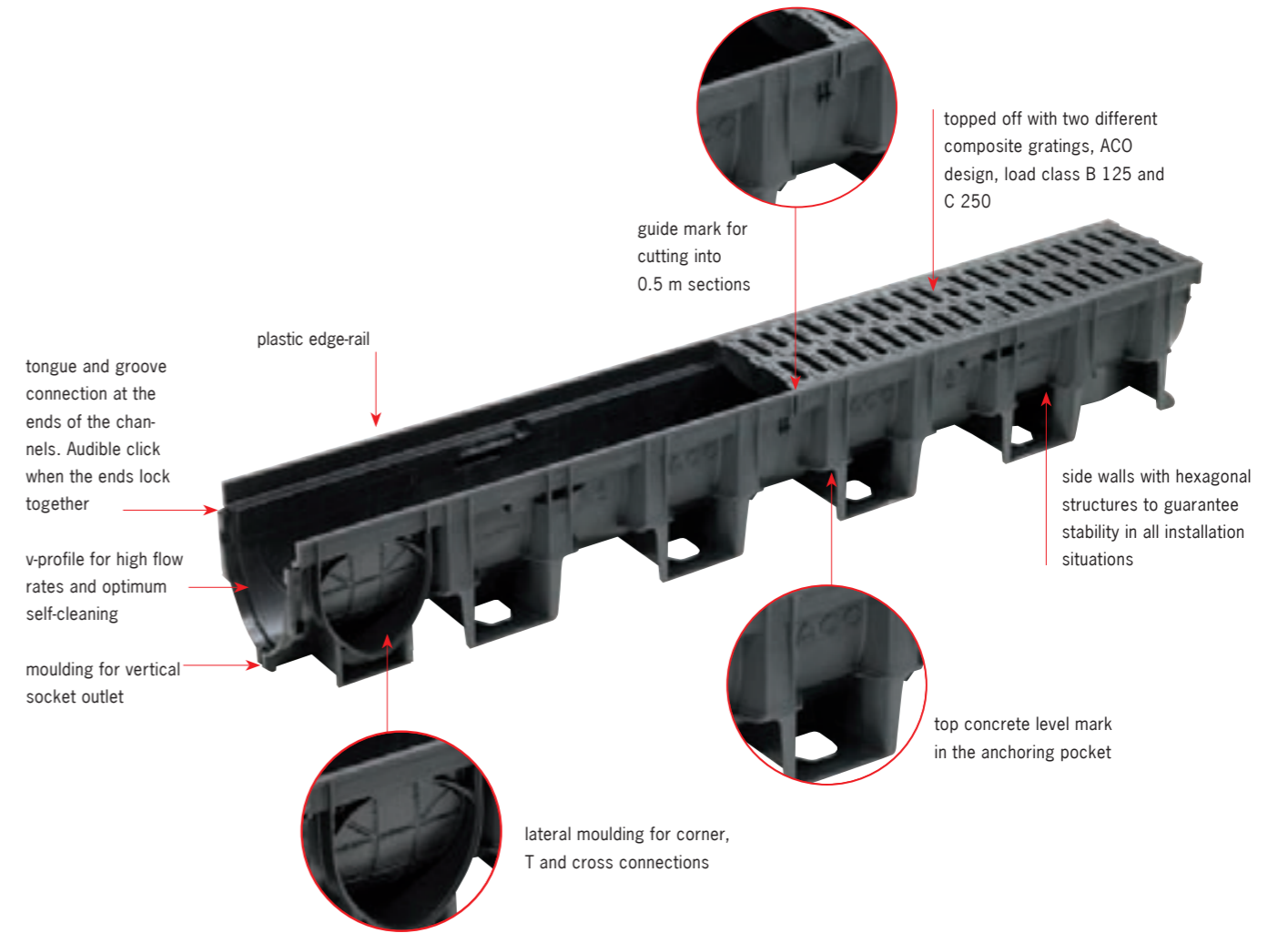

ACO composite channel

Manufactured from recycled polypropylene, the high quality, high strength unit is available in three channel widths; 100 mm, 150 mm and 200 mm. As standard channels are manufactured with galvanised steel or composite edge rails - which provide optimum channel protection from vehicular traffic.

It is possible to choose from a range of traditional and discreet slot drainage gratings and solid covers to ensure that a wide variety of applications are cate-

red for. The system's gratings are fitted with ACO Drainlock, a bar-less locking device which reduces the risk of blockages and improves hydraulic capacity.

ACO XtraDrain system also has a range of Brickslot gratings to complement installations which require a discreet drainage system. ACO Brickslot gratings are available in galvanised or stainless steel and are suitable for use with the 100 mm and 150 mm wide channels in the ACO XtraDrain range.



Typical applications

- Footpaths, pedestrian areas
- pedestrian precincts
- public and private car parking spaces
- open spaces around business premises such as banks, insurance companies, hospitals
- housing areas/estates
- schools
- railway station entrances
- façade drainage
- railway platforms



XtraDrain channel is available with galvanised edge

ACO point drainage – removing water is a point not to be missed



ACO point drainage systems are ideal for surfaces which require point drainage for structural or topographical reasons.

A range of surface drainage products engineered uniquely for highways, urban roads and bridges

ACO road gully Combipoint

A flexible modular system for wet sludge and dry sludge road gully units.

Typical applications

- kerbs
- traffic lanes
- car parks and industrial surfaces
- school yards
- pedestrian zones

Benefits

- rotatable – for optimal pipe-connection
- telescopic – for flexible height adjustment
- load decoupled – to avoid settling
- no mortar joints, therefore without weakness
- light units – easy handling during installation



ACO DRAIN® point drains

Yard drain made of polymer concrete, topside ductile iron frame, inset ductile iron grid and Pointlock boltless locking

Typical applications

- roads, paths, piazzas
- car parks
- railway platforms
- school yards
- industrial areas
- airports



The riser units Multitop are available with a channel or flat profile. Available in two universally applicable dimensions. 300 x 500 channel shape and flat shape. 500 x 500 channel shape and flat shape. In accordance with EN 124/DIN 1229. The riser units match all discharge combinations in accordance with DIN 4052.

ACO riser units Multitop

The new riser unit designs for class C 250 to D 400 Multitop storm water discharges feature long service lives, easy handling and simple maintenance. The frames and grates are made of ductile iron. The most important detail is the unbreakable maintenance-free double hinge which allows the grid to be folded out to around 115 degrees on either side or completely removed. 4-point vibration absorption integrated within the frame reduces rattling noises. Other features include the low weight of the grate and the easy to operate grate securing system using a boltless non-corroding spring lock for the first time. Because the system is self-locking, there is no danger of vandalism.



Typical applications

- kerbs
- traffic lanes
- car parks and industrial surfaces
- school yards
- pedestrian zones

ACO Bridge discharge system

High specifications are laid down for bridge drainage systems because of the greater risks to traffic and the need to protect expensive infrastructure. Bridge drainage systems also have to match the special features of bridge construction such as reinforced concrete bridges, and special construction measures such as timed shifting when constructing large steel bridges. ACO bridge discharge systems fulfil these requirements:

- they comply with class D 400 in accordance with EN 124
- the grate is firmly fixed into the frame with a hinge
- the grates are locked or bolted to prevent unauthorised opening

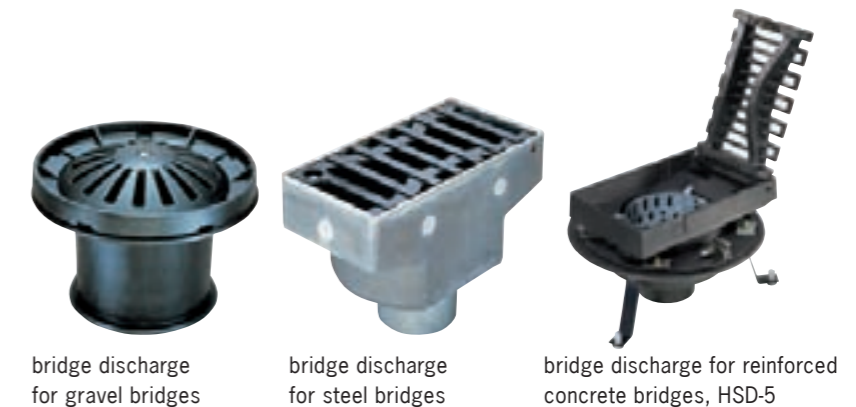

bridge discharge for gravel bridges

bridge discharge for steel bridges

bridge discharge for reinforced concrete bridges, HSD-5

Manhole covers – ductile iron



The brand new concept for manhole covers: MultiTop class D 400 in accordance with EN 124. The focus of the new technical concept is safety, weight and maintenance-friendliness. All are incorporated in the new manhole covers developed by ACO.

Typical applications

- roads, paths, piazzas
- airports and ports
- control shafts



The new ACO manhole top program with ACO CityTop, ClassicTop and MultiTop



For tomorrow's infrastructure –

ACO manhole covers: CityTop, ClassicTop and MultiTop

Operational safety, durability and cost efficiency are the main criteria defined for high traffic infrastructure. With the ACO range of manhole covers, top sections and inlet gratings, ACO satisfies all specifications pursuant to DIN EN 124/E DIN 1229. Intelligent product features such as lightweight covers and gratings, boltless locks, damping frame inserts, and hydraulic, optically attractive and technically sophisticated surface designs, underpin the ACO Manhole product line's high engineering standards.



CityTop Bituplan

Benefits

- durability and reliability
- high securing level and long lifetime
- user-friendly and safe in operation

Cover features

- ClassicTop is secured by highest mass per unit area
- CityTop and MultiTop are secured by screwless and maintenance free locking devices
- two anti-theft devices can be installed to prevent theft of CityTop

Frame features

- a cushioning insert is placed in the frame of all ACO manhole tops
- Bituplan frames offer highest load transfer to protect mortar bedding and shaft top
- a mobile entry-facility tool is firmly fixed in Multitop Lift or Bituplan frames



Maintenance-free, boltless, traffic-proof lock made of heavy-duty wear-and-tear resistant plastic in accordance with EN 124



Operation simplified by reducing the cover weight by more than 50%

ACO access and manhole covers – multiple and recessed covers for shafts and supply ducts

ACO has a wide spectrum of high-precision access covers and riser units for all load classes and for the complete range of shaft and sewage structures. The single and series covers use high quality technology to lengthen service lives and reduce operating costs.



Servokat access covers for emergency exits

Typical applications

- telecommunication installations
- airports and ports
- railway stations
- tunnels
- bridges
- emergency exits
- water and gas supplies
- control shafts
- water treatment and sewage works

Servokat access covers in stainless steel and galvanised steel. For load classes B 125 and D 400. Standard sizes 600 x 600 up to 1500 x 1500. Other sizes upon request



The **Servokat access covers** with easy opening features are the ideal solution for access shafts which are frequently opened for maintenance and inspection purposes. High quality is guaranteed by the ability to integrate the access cover in a wide range of paved surfaces. Servokat access covers comply with all safety regulations.

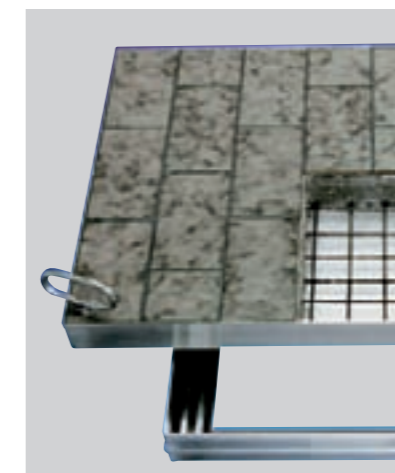

The **recessed access covers** for customised surfaces can be ideally adapted to the local surface covering by inserting the paving required into the lid of the access cover. The cover can be filled with conventional paving and surfacing materials (tiles, flagstones, granite, marble, laminated wood, carpets or other materials).

Recessed-access covers in stainless steel. Also available in galvanised steel and aluminium. Suitable for indoors and outdoors. Standard dimensions 300x300 to 1000x1000. Other sizes upon request



Secant access covers in variable sizes with choice of surfaces. For load classes B 125, D 400 to F 900. Also available as covers filled with concrete and iron

The **Secant access covers** available in various lengths and are a very flexible access cover system because the design and the materials open up an enormous range of applications.

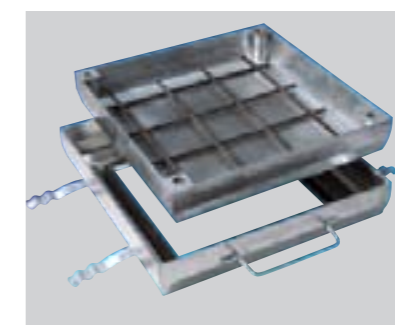

ACO TopTek covers are the ideal solution for secure and discreet covering of shafts in the floor. TopTek covers are manufactured from aluminium alloy, mild steel, hot dip galvanized or stainless steel

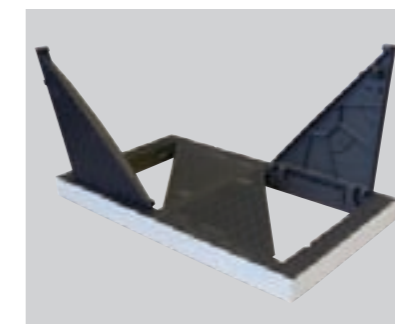

TRIGONA – the new cable shaft cover with triangular trap doors. Optimum design, innovative technology and efficient material selection guarantee easy opening and closing of the individually removable trap doors which are rattle-free thanks to the triple-point supporting frame. The weight of each individual door is reduced to less than 25 kg – TRIGONA can therefore be operated by one person without any additional lifting gear. The self-locking door cannot close accidentally. The safety lock and self-cleaning hinges are made of ductile iron to prevent stress corrosion or contact corrosion.

ACO tree grate systems – offering optimum protection to street trees



Healthy vegetation and great optical appearance: Both aspects may be achieved with the ACO tree protection systems. Tree grates and tree protective cages equally ensure trees retain their living space even in densely populated urban centers.



The WOTAN tree grate permits additional fastening of poles or tree trunk protection frames



Matching tree protective cages made from galvanized steel in various colors, heights and designs are available; illustrated is a height of 182 cm

WOTAN System

The WOTAN System, proven for many years, offers flexibility in form and size. The WOTAN requires no substructure. The base module consists of a partial grate, 6 cm in height, is manufactured from maintenance-free ductile iron. Individual modules are connected together using a theft-proof toggle lock to provide a load bearing surface.

Standard System

The ACO Tree Grate Standard System consists of round and square tree grates of 125 – 300 cm size. Radial and ray designs offer additional design options. Up to a size of 200 cm, the standard ACO Tree Grate consists of four individual units. One unit is provided with a watering hole cover. All versions are available for non-braking tire loads of 15 kN up to 50 kN.

Typical applications

- street trees
- trees in urban areas

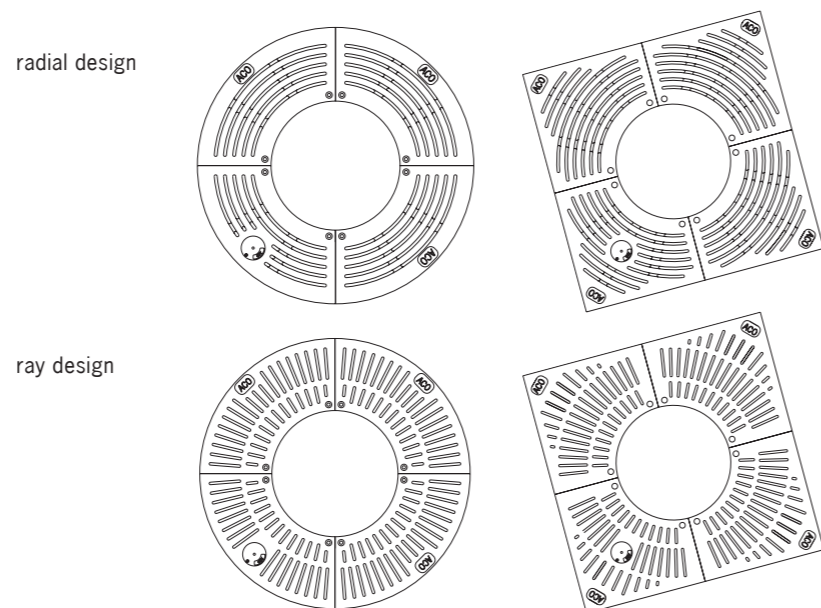

ACO grass grid – pro nature

Green areas represent an absolutely vital part of our existence. The sealing off of occasional use traffic areas cut off this livable space.



Park use of grass grid



Parking space reinforced with grass grid

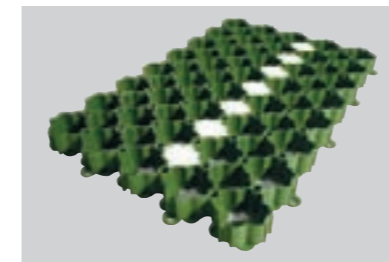

ACO grass grid



ACO grass grid used as large-scale reinforcement of fire rescue access route

The continual building of towns and construction of paved areas means less and less natural ground drainage. To cope with this, we require bigger and more expensive water treatment systems to deal with the water collected in sewers. Therefore, there is an increasing necessity for large-scale seepage of rainwater back into the ground. Many industrial nations have listened and are attempting to counteract the sealing off of surfaces through building restrictions and regulations for sealed surfaces.

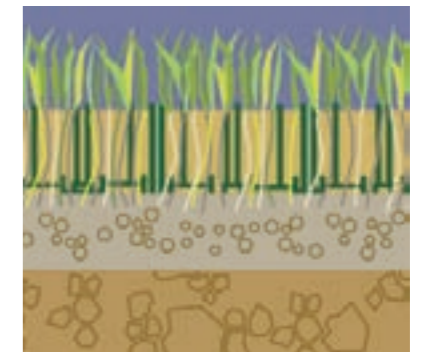

Typical applications

- parking spaces
- domestic driveways

ACO grass grid is made from plastic, provides unsealing of parking lots, yard driveways, terraces, walkways, storage spaces, emergency routes and river bank reinforcements. These areas will remain green, yet are still load-bearing. Through the use of recycled materials, ACO promotes the environmental issue. When sealed surfaces are required to aid area seepage, the

surface drainage systems such as ACO Self® or ACO DRAIN® can be used. ACO grass grid is lightweight, thus easily transported, and for installation they snap together. While regionally varying, many building regulations require a certain amount of "green" area. Using grass grid allows vehicular use of these areas.



ACO amphibian protection – ACO wildlife



Constructing wild animal protection systems is a safe, effective measure for wildlife. Efficiently linking habitats with safe corridors requires custommade construction solutions.

Amphibians and small animals occupy a wide range of habitats which are often divided by roads. Amphibians in particular undertake seasonal migration between land habitats and their vital spawning grounds. Because they move slowly, and can spend a relatively long period on the roads that they cross, many amphibians and other small animals are doomed to join the countless victims of road-kill. Animals undertaking mass migrations at the end of winter, or in the

summer after thunderstorms, experience a very high risk of being hit by vehicles. There is even a danger of complete eradication of local animal populations. In addition to animal protection is the risk to drivers and passengers from animals on roads, when vehicles swerve to avoid them. Public safety and species protection are mutual benefits from the Wildlife protection systems designed by ACO.

ACO Climate tunnel with Entrance unit and guide wall made of polymer concrete

Safe crossings for amphibians in particular, are dependent on several factors: it is important for the length of the tunnel to be as short as possible; the material must not remove moisture from the animals; the temperature in the tunnel should be close to the ambient temperature; and to prevent any disorientation, the components should not contain any metal. The ACO Climate tunnel KT 500 satisfies all these factors because it is made of polymer concrete. This system can also easily cope with high groundwater levels and roads in cuttings.



Climate tunnel KT 500, Entrance unit KP 1000-700 and Guide wall LEP 100

Entrance unit KP 1000-700



Climate stilt tunnel KST 500-700



Climate tunnel KT 500 with/without climate slots

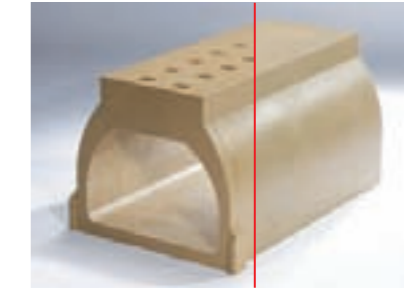

Entrance unit

Amphibians, reptiles and small mammals reach the entrance to the tunnel – the ACO Entrance unit – by following the guide wall system. Thanks to its internal width of 1000 mm and a variable height of 500–700 mm, the Entrance unit can be optimally adapted to suit the local topography. After installation in the embankment, the surface of the tunnel entrance unit aligns neatly at the same level as the top edges of the side walls.

Climate tunnel with or without climate slots

The Entrance unit and the attached Climate tunnel or Climate stilt tunnel, form an integrated tunnel environment, fitted with slots at ground level which allow the internal temperature, relative humidity, ground moisture and light to adjust rapidly to the local outdoor conditions. These tunnels are therefore not affected by “central tunnel dryness” problems and also serve to reduce airflow through the tunnel. Climate tunnel elements without a slotted roof can be installed along some stretches such as under the main road traffic lanes. The surface layers close to the surface can be just 80 to 200 mm thick.



Compensating for height differences

Guide wall

The crucial transition zone to the tunnel is formed by the ACO Entrance unit together with the adjacent ACO Guide wall elements. The entrance is cone-shaped to guide the animals into the tunnel. The ACO Guide wall system made of polymer concrete consists of five profiles: straight, interior and exterior curves, and rising and falling elements to cope with changes in height. The components are all laid manually. Almost all fence layouts routes can be formed without cutting. The Guide wall LEP 100 has a double guard to prevent animals from climbing up and over it. Narrow vertical slits drain the filled area at the back of the fence. This effectively prevents saturation of the verge and any associated reduction in its load-bearing strength.



Amphibian protection and tree protection



**ACO SPORT drainage systems –
for running tracks and sport facilities**



ACO SPORT elements in London. ACO has provided drainage systems for all the Olympic stadiums since the Olympic Games in Munich 1972, with the exception of Moscow

ACO SPORT includes drainage systems and construction elements for sports and recreational facilities, helping them to remain in good playing condition throughout the year.



ACO SPORT slotted channel LW 125 can be coated on site with ET track cover, no abutment rail



ACO SPORT slotted channel LW 125, with aluminium edge-rail design

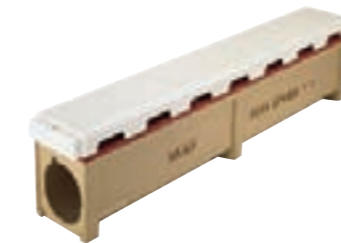

ACO SPORT slotted channel LW 125, curved 1 m, with cover, suitable for abutment on two sides by synthetic surface

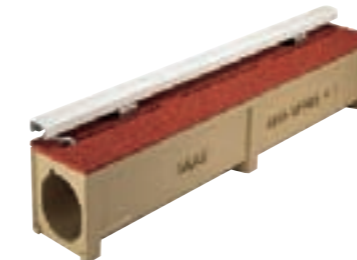

ACO SPORT slotted channel, coated with synthetic track surface and moveable edge-rail

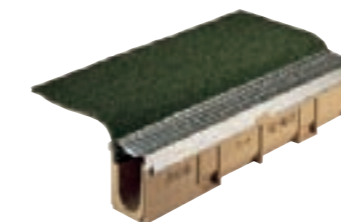

ACO SPORT channel with independent turf clamp



ACO SPORT artificial turf drainage system 6000

Safety is the goal at every level

The ACO SPORT 1500 drainage system safely drains water away from running tracks and pitches for type A – D sports arenas.

ACO SPORT LW 125 slotted channels are the preferred solution for draining running tracks where a seamless transition between track and playing field is required.

The installation of slotted channels instead of grated channel systems permits the use of playing fields for a variety of sports without the limitations associated with a permanent raised edge.

The channel system is manufactured from polymer concrete, a material characterised by extreme durability and stability to guarantee long service lives. Quartz-type fillers and polymer resins render this material watertight – an ideal environmentally compatible material with superb properties.

ACO SPORT system 1500 is manufactured in compliance with DIN 18035 Part 3 and IAAF regulations. It also complies with FIFA regulations for football pitch drainage. This channel system has the following special features:

- smooth interior surface enabling high flow velocities and capacity
- high self-cleansing effect
- wide channel width at the base for secure placement in poured concrete foundations
- coatable with 13 mm synthetic track covering
- standard radius $r = 36.5$ m
- low weight and easy installation
- installation assisted by directional arrow markings
- braced drainage slot prevents compression during installation
- installation alignment assisted by tongue and groove system at channel ends
- suitable for wheelchair use



ACO SPORT system 1500 with slotted channel LW 125 used as drainage system for running tracks



ACO SPORT system elements for hockey pitches

ACO DRAIN® drainage system for spectator stands



ACO SPORT construction elements and accessories

Construction elements used in playing fields for track and field sports must be clearly defined and functional to ensure that sports can be conducted safely and to simplify maintenance and operating costs. ACO SPORT includes edging and construction elements or functional sports field operation.

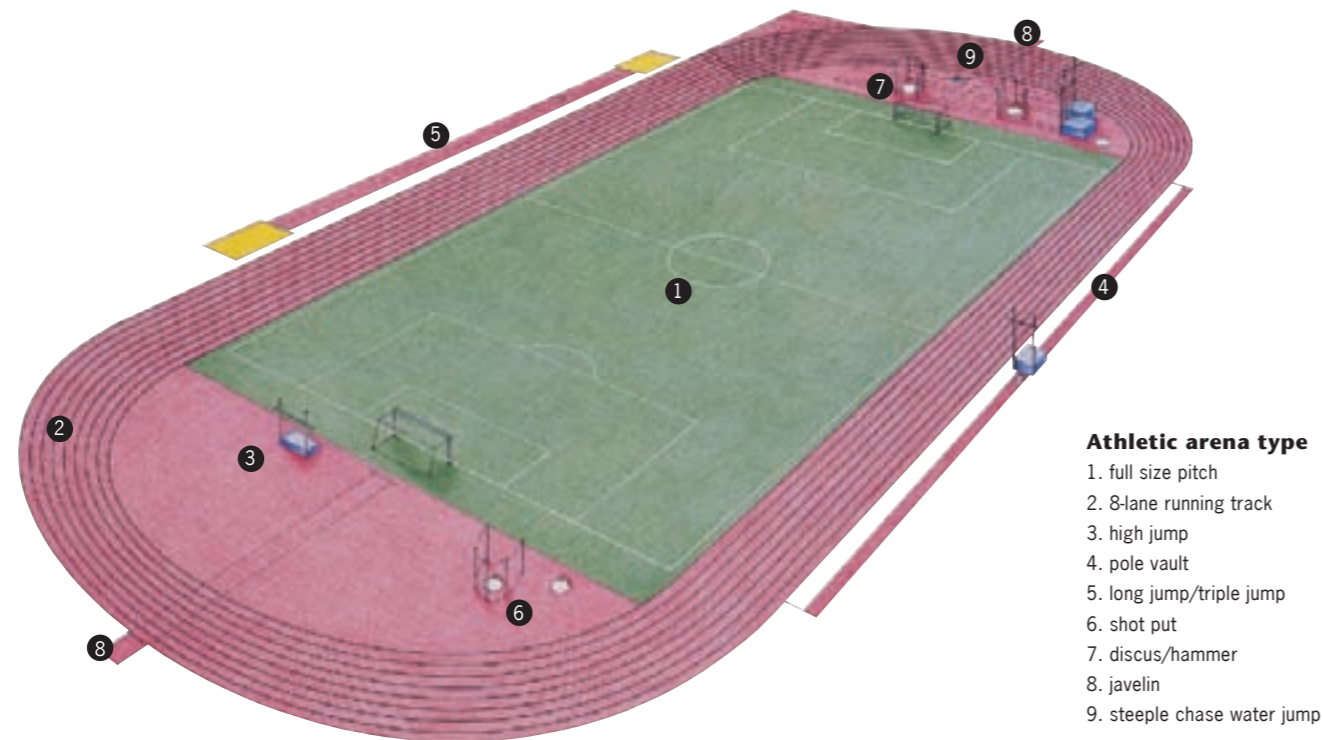

Athletic arena type

- 1. full size pitch
- 2. 8-lane running track
- 3. high jump
- 4. pole vault
- 5. long jump/triple jump
- 6. shot put
- 7. discus/hammer
- 8. javelin
- 9. steeple chase water jump



ACO SPORT system 8400
Distribution shafts for electrical and communications equipment, fixtures, measuring equipment and water supplies

Top performance in all safety aspects

Perimeter systems for playing fields, running tracks, jumping pits, throwing and shot put facilities, roller sports and boccia pitches, as well as construction elements for pole vault and steeple chase are as much a part of the system as the supply shafts. Every new sports arena raises new challenges for planners. Planners have to take local conditions into consideration as well as the wishes and needs of the owners, clubs and users.

ACO Service provides free solution recommendations for its sports field systems – right from the start of the planning process. Even during the preparatory phase for the construction documentation, ACO provides precise CAD layouts, parts lists, installation recommendations and tender proposals to assist in precise cost determination.



ACO SPORT sand trap channels enclosing the long jump pit



ACO SPORT system 7000
Sand trap channels and elastic perimeter kerbs enclosing the long jump pit. They hold back the sand and keep the running track clean

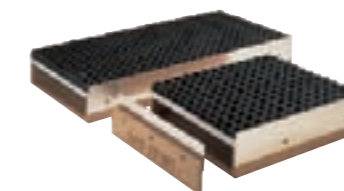

ACO SPORT sand trap channels with edge-rails



ACO SPORT elastic perimeter kerbs safely enclose the running track, the pitch, long jump pit and the shot put area



ACO gravity and siphonic roof drainage



Flat-roof gullies are installed to drain rain water from roofs, car park decks and terraces. The collected rainwater is drained off via internal drain pipes.



ACO roof gullies SPIN in cast iron

ACO SPIN – Gravity roof drainage in cast iron and stainless steel

Gullies with pressed sealing flanges but without foul-air traps are used for the efficient drainage of roofs. ACO's modular system for this purpose consists of gullies with nominal widths of DN 70, DN 100, DN 125 and DN 150, in one-part or two-part models, plus accessories. With the exception of the optional components for green roofs, the components are manufactured from grey iron to EN 1561.

- Product benefits**
- variable modular system suitable for different roof constructions
 - heatable flat-roof gullies
 - gully body with pressed sealing flange for connection to different types of sealing membrane
 - non-flammable housing
 - good connection between concrete and cast-iron



ACO roof gully SPIN in stainless Steel



ACO JET – Siphonic roof drainage in stainless steel and cast iron

Safe, rugged and high capacity are the trademarks of JET roof gullies in cast-iron and stainless steel for the siphonic drainage of large roofs, e.g. shopping centres, industrial warehouses or offices.

- Typical applications**
Large roofs such as:
- shopping centres
 - industrial warehouses
 - football stadiums
 - office and administration buildings

- Product benefits**
- massive pressed sealing flange connections to interface up with the sealing membranes
 - good connection between concrete and metallic gully body
 - weather resistant and UV-proof
 - resistant to damage during construction
 - non-flammable
 - high discharge capacity: DN 50 approx. 9 l/s, and DN 80 approx. 17 l/s



ACO flat roof gully JET of cast iron for siphonic drainage from DN 50 to DN 80.



ACO flat-roof gully JET in stainless steel
In nominal widths DN 40 to DN 100

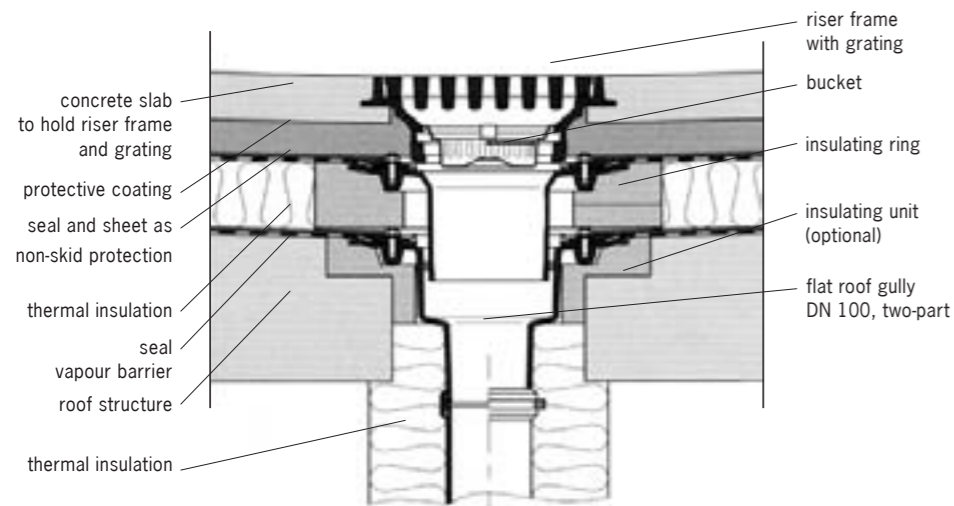

Installation example: park deck, thermally insulated, with 2-part flat roof gully DN 100

Typical applications

- flat roofs
- terraces
- hospitals
- shops
- car park deck drainage
- green roof drainage

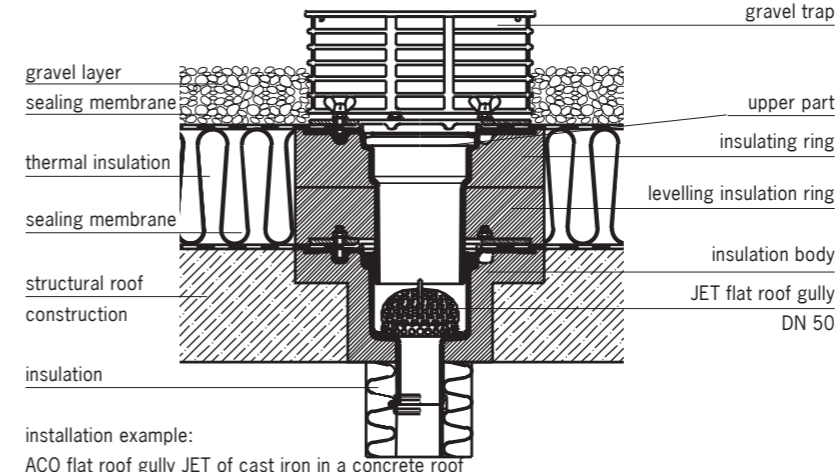



ACO pipe work systems and balcony drains of stainless steel and galvanised steel

The functional strength and service lives of sewage pipes are being increasingly challenged by the rising level of technology in homes, the growing demands for more housing and sanitation comfort, and the presence of aggressive media in domestic wastewater. ACO rises to this challenge with a complete programme of pipes, fittings and gullies in stainless steel and galvanised steel.

Stainless steel pipe system

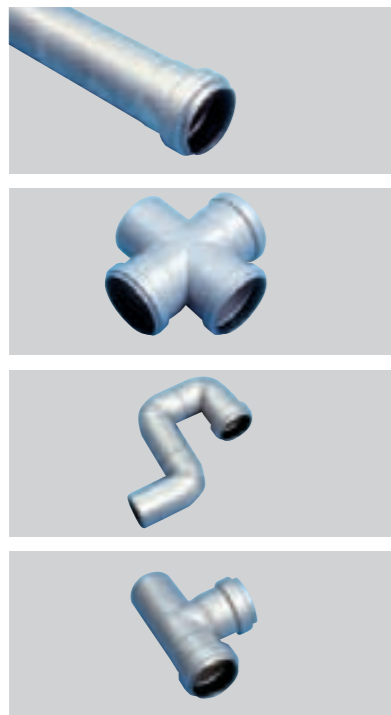

Manufactured from grade 304 austenitic stainless steel as standard, ACO stainless steel pipe is ideal for most liquids including soil, wastewater, process water and rain water. Grade 316 stainless steel pipes and fittings are optionally available for particularly aggressive industrial drainage applications. The range is completely compatible with ACO stainless steel floor gullies, channel systems and rainwater drainage products.



ACO PIPE double-lip sealing system
Double-lip seal function principle

Benefits

ACO PIPE stainless steel pipes save on installation costs and long-term care and maintenance

- highly corrosion resistant
- light and easy to handle
- very reliable double-seal joining system
- simple push-fit assembly
- low expansion coefficient
- attractive

Typical applications

- ACO PIPE stainless steel pipe is the fast alternative to cast iron or PVC pipe systems, and is available in standard pipe sizes with easy to assemble push-on fittings.

ACO stainless steel pipes and fittings

Available in sizes 50 mm, 75 mm, 110 mm and 160 mm external diameters, with pipes supplied in standard lengths 0.15 m, 0.25 m, 0.5 m, 0.75 m, 1 m, 1.5 m, 2 m and 3 m for optimum practicality and easy assembling. Pipe lengths up to 6 m can also be easily supplied in line with specific customer applications.

Galvanised steel pipe system – GM-X

Pipes and fittings made of welded, precision steel pipes, cold-drawn in a single process in accordance with EN 10305-3. Steel is fracture-proof, non-deformable, heat and frost resistant, non-flammable, and has favourable noise characteristics.

ACO produces a complete product line of steel pipes and fittings in nominal widths from 40 to 300 mm.

GM-X drain pipes

In galvanised steel, internal plastic coated, nominal widths DN 40 to DN 300.



Typical applications

- domestic wastewater installations: connection pipes, downpipes, collection pipes, groundwater pipes, ventilation water pipes and rainwater pipes.

Benefits

- low noise emissions
- extraordinarily low thermal expansion
- fire-resistant in accordance with DIN 4102 and DIN 1986.
- corrosion protected
- shock-proof and impact-resistant

Balcony drains made of stainless steel

Modular construction

Different solutions are required depending on the installation situation when planning modern balcony and terrace drainage systems. ACO's balcony and terrace product line is therefore intelligently designed around a modular system

Everything starts with the drain bodies: depending on the model, drains with vertical or horizontal outlet sockets can be supplied. And depending on the model, the drain body can be combined with intermediate sections and a range of top section systems which allows the right drainage solution to be created for each application and floor structure.

Typical applications

- balconies
- terraces



ACO Floor gullies – a wide range of multi-application and high performance products



ACO's product line includes a broad range of height-adjustable floor gullies suitable for any type of floor. Drainage is vertical or horizontal. The ACO modular system has a large number of flexible combination options for every installation situation.

Floor gullies in stainless steel

EG 150 range of Eurogullies are designed as hygienic, quick, simple and economic trapped drainage solutions. Suitable for all floor finishes including cement and resin screeds, ceramic tiles, and flexible vinyl flooring. In solid floors and suspended floors.

Manufactured in austenitic 304-grade stainless steel as standard with guaran-

teed excellent corrosion resistance. Optional 316-grade stainless steel for very aggressive applications. EG 150 Eurogullies are supplied with gratings as standard which are completely safe for bare feet or stiletto heels. A non-slip or plain mesh grating is available for cement/resin screeds and tile applications.



ACO EG 150 Range for cementitious/resin screed and ceramic tile application

Typical applications

- light industrial use
- toilets, washrooms, wet bathrooms
- hotels, apartments
- swimming pools

Floor gullies in cast iron – Wal-Selecta



Cast iron is still the number one for planners, developers and plumbers because of its functionality, reliability and safety in building drainage applications. Floor-level cast iron gullies are:

- non-flammable
- sound insulating
- long lasting
- completely recyclable

Plastic floor gullies

The plastic floor gullies are part of a modular system allowing various combinations in the nominal widths DN 50, DN 70 and DN 100. The perfect solution can therefore always be put together to match each situation and application. All of the risers in the WAL-SELECTA DN 50/70 product line can be used with this system.



ACO plastic floor drains with top sections and stainless steel design gratings

Typical applications

- bathrooms and toilets, washrooms
- domestic/residential use

- have the same coefficient of expansion as concrete
- in nominal widths DN 50, 70 and 100
- with or without fire protection set

Typical applications

- technical facilities
- industrial buildings

Fire protection floor gullies

ACO WAL-SELECTA fire protection floor drains R 30 to R 120 with odour seals and vertical outlet sockets

The WAL-SELECTA and VARIANT- CR fire protection floor drain series are made of inflammable cast iron or stainless steel. A replaceable and retrofittable fire protection kit is fitted into the floor drains. The fire protection kit varies according to the floor drain and consists of a fire protection odour seal with intumescent material in the head. This ensures safe sealing of the floor drain during a fire to prevent fires spreading from above the

ceiling to below the ceiling. There is also a fire protection cartridge containing intumescent material which securely blocks off the floor drain and prevents fire spreading from beneath the ceiling to the floor above.

"Preventative fire protection for all floor gullies" has attracted an increasing amount of interest in recent years – particularly for installation in buildings for special uses, e.g. hotels, hospitals, care homes or schools – where fire-resistance specifications already exist for ceilings and floors.



Fire protection set DN 50/DN 70 and DN 100



Function of the ACO Haustechnik fire protection floor drains before a fire



If a fire is present beneath the ceiling, the intumescent mass in the cartridge safely blocks the socket in the drain



A fire on top of the ceiling expands. The intumescent mass in the odour seal to completely block the drain

Typical applications

- hotels
- hospitals
- care homes
- commercial and industrial buildings

- 1 ACO WAL-SELECTA fire protection floor drain DN 70
- 2 ALL PURPOSE odour seal with heat shield
- 3 fire protection cartridge with intumescence mass
- 4 AV-SELECTA, PP top section
- 5 sealing ring

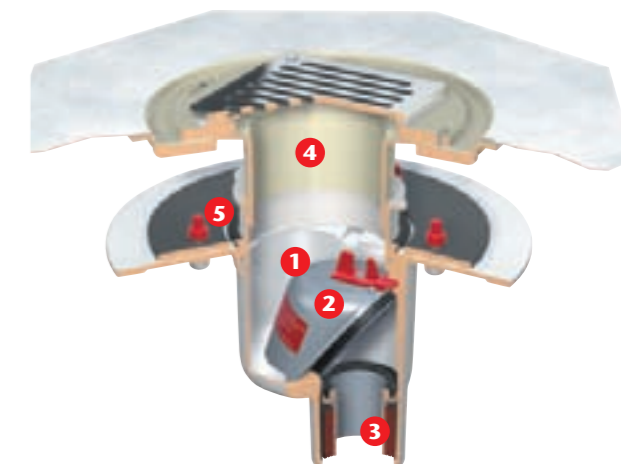

ACO shower channels – architecturally attractive solutions



Shower channels as design elements

The Showerdrain is a channel built into the shower floor which beautifully combines form with function. The Showerdrain is the perfect high quality solution for high-class bathrooms featuring glass fixtures and natural stone floors, as well as public applications where the absence of barriers is an important consideration. The rigid channel body manufactured from stainless steel has a lateral channel gradient to ensure positive drainage of the water.

Cleaning
The removable foul-air trap is also manufactured from stainless steel and is designed for simple cleaning and the effective prevention of odours.

Grating design
Various grating designs are available in finely polished stainless steel to decorate the visible part of the channel. ACO Showerdrains are available in standard lengths from 700 to 1000 mm. The Showerdrain is an attractive alternative to a conventional shower tray in high-class bathrooms as well as in public areas.



Showerdrain with "wave" designer grating



Simple cleaning with the removable foul-air trap

Function and design are combined perfectly in the ACO Showerdrain and the ACO designer gratings. The high-quality stainless steel look of the channel and the gully satisfy sophisticated demands for continuous level floors.

ACO Showerdrain Lightline – the first illuminated shower channel

The ACO Showerdrain Lightline illuminated shower channel turns a functional part of a shower into an active bathroom design element. Combining function with design, this customised channel is made possible by another innovation: the aqua-sensitive LED lighting. The combination of high quality electro-polished

stainless steel gratings, water, and coloured LED lighting, creates a completely new shower environment. This new channel succeeds in combining simple installation and cleaning, with totally elegant design, topped off by stunning optical effects.

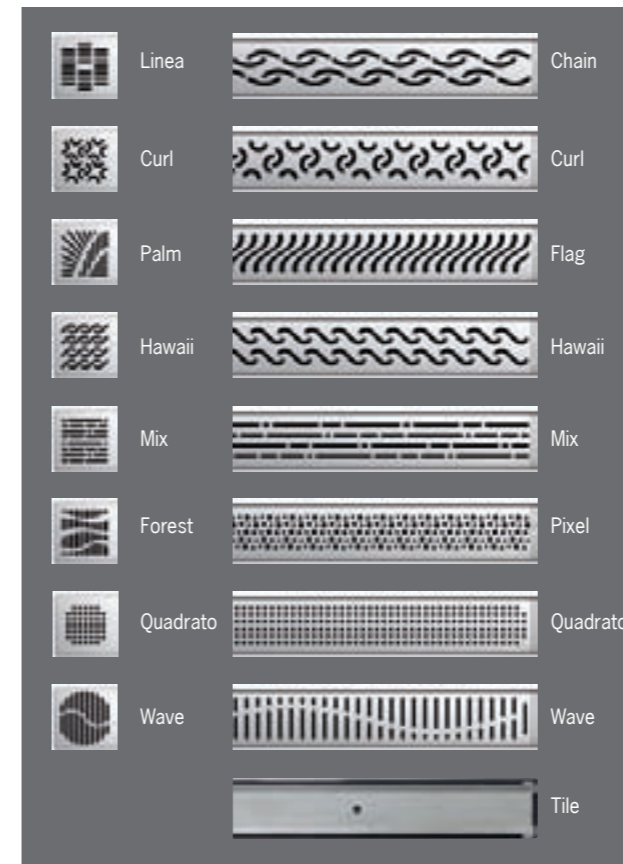

ACO Showerdrain in a floor-level shower

ACO designer gratings

The ACO stainless steel designer gratings are laser-cut and have an electro-polish finish. They are elegant, individual and superbly functional. The gratings fit the 150 x 150 mm and Ø 136 mm frames and are therefore used as standard with the MEKU or AV-SELECTA PP risers from ACO for the thin mortar bed sealing method. The risers can be combined with all ACO cast iron and stainless steel gullies in sizes DN 50 and DN 70 on the plastic floor gullies DN 50-100. ACO designer gratings can also be individually made to customer specifications. In addition to the patterns shown here, any other pattern can be cut out and customised from stainless steel plate.



Left: AV-SELECTA-PP risers for thin mortar bed installation. Right: plastic risers with partially telescopic height-adjustment for optimal adjustment with the flooring.

*Designer gratings are illuminatable in red, blue, green and warm white

ACO stainless steel drainage



Stainless steel is the ideal material for applications where cleanliness and hygiene are the highest priority.

Because of its high strength, good metal-forming properties, corrosion resistance, and its smooth permanently attractive surface, stainless steel is highly prized as an extremely high quality, durable and hygienic material. It is virtually completely resistant to dirt, preserva-

ves, micro-organisms and the proteins found in meat, blood, fat and drinks, etc. Proteins and bacteria do not readily adhere to the smooth surface and can be easily removed with suitable cleaning products and disinfectants.



VARIANT-CR channel with floor gully and adhesive flange, or pressed sealing flange, set level with the bare concrete floor

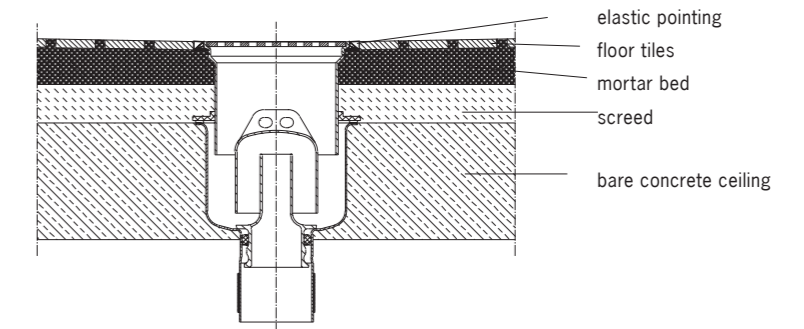

Installation example: Floor gully DN 70 with retaining edge



Installation example: Sealing vinyl sheet flooring against drainage channels and gullies

Stainless steel drainage channels

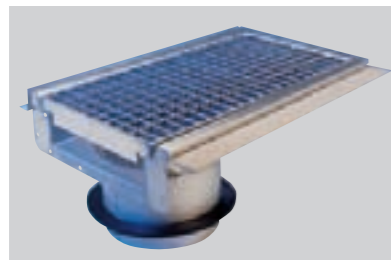

Drainage channels

A welded construction available upon request in various channel widths and channel lengths with customised pipe connections. Drainage channels with widths of 150 mm, 300 mm and 450 mm are produced as standard in 500 mm lengths ex warehouse.



Slotted drainage channel

slotted channels are supplied ex-works in lengths of 1000 mm, 2500 mm and 5000 mm. Customised solutions can be easily manufactured upon request.

Product benefits

- channel widths from 150 mm to 500 mm
- special edge profiles for abutment with tiles, artificial resin/mortar floors and thin mortar bed seals
- range of gratings and covers for classes L 15 and M 125
- all stainless steel parts pickle passivated to ensure full corrosion protection.

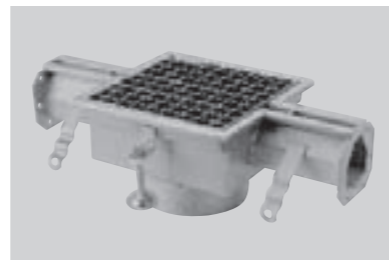

Modular 1000/2000

A wide range of high quality channels, gratings and industrial gullies, manufactured from 2 mm thick austenitic stainless steel provides practical solutions for floor drainage problems.

Customised solutions upon request

- customised channel widths
- material grade 316
- extra-flat models
- section types: NF, NFH and NK

Stainless steel floor gullies



Floor gullies

Consists of floor gully units with nominal widths from DN 70 to DN 150, and risers with a range of gully gratings suitable for classes K 3 to M 125.

Available with fire protection sets for fire resistance classes R 30 – R 120



Product benefits

- sophisticated modular system with floor gullies from DN 70 to DN 150
- special AV-VARIANT riser element for thin mortar bed sealing
- floor gullies with retaining edge, adhesive flange and pressed sealing flange
- all stainless steel parts pickle passivated in submersion baths
- calibrated pipe connections for direct connection to SML pipe
- non-slip gully gratings
- all gullies directly combinable with our drainage channels in stainless steel

Special models upon request e. g.:

- risers with round gratings
- gullies with lateral inflows
- material grade 316

Typical applications

- industrial kitchens in canteens, hospitals, care homes, businesses, catering companies
- pubs, restaurants, fast food outlets, cafeterias
- abattoirs and meat-processing industry, butchers
- food and drink industry
- pharmaceutical industry, cosmetics industry
- swimming pools and leisure industry

Stainless steel grade 304 and 316 are usually used for these applications.

ACO Passavant grease separators – Fully developed products compliant with international standards



Grease separators need to be adaptable and versatile, and be available in various sizes and materials to meet the enormous range of different industrial and commercial needs.

ACO has many years of experience in the production of grease separators. Its comprehensive product line includes free-standing and underground grease separators. Precise engineering and in-depth expertise guarantee fully developed, quality-assured and completely tested products that satisfy all international standards.



The ACO product line has an optimum solution for every application. Free-standing grease separators are manufactured from stainless steel or polyethylene. In addition to the two materials, there are also two disposal systems: partial and full disposal. Partial disposal only involves disposal of the grease and solids – this is carried out by ACO's manually operated LIPATOR or the fully-automatic LIPATOMAT. Partial disposal saves water and disposal costs. Full disposal grease separators remove all of the contents.

Underground separators are made of reinforced concrete or polyethylene. The ECO-FPI is the first and only grease separator made of polyethylene with SLW 60 static certification – it therefore requires no concrete strengthening around the cover plate.

Typical applications

- meat processing
- kitchens
- restaurants
- grilling, roasting and frying kitchens
- motorway services
- catering facilities

Full disposal



LIPURAT, oval, automatic or manual control with disposal pump, optional remote control, high pressure internal cleaning, modular construction.



ECO-JET with or without direct vacuum extraction, optional fill sensor, low weight, modular construction

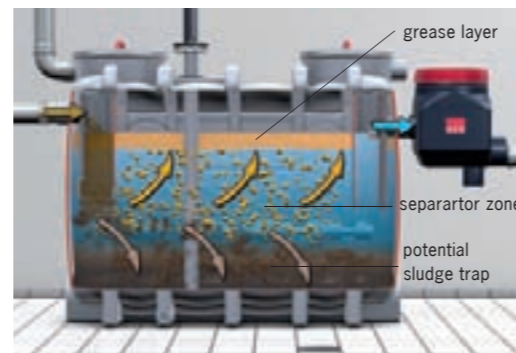

Full-disposal principle

EN 1825 function diagram
Grease separator with no separate sludge trap and separator

Partial disposal

The main applications of this type of grease separator are restaurants, canteens and catering operation kitchens. The grease collects in the upper cone. The sludge sinks to the bottom of the lower cone. The grease is kept fluid by heating the upper cone



LIPATOMAT fresh grease separators in stainless steel and programme control for free-standing installation

Typical applications

- ships
- areas with difficult access for disposal vehicles
- combined with wet refuse disposal equipment

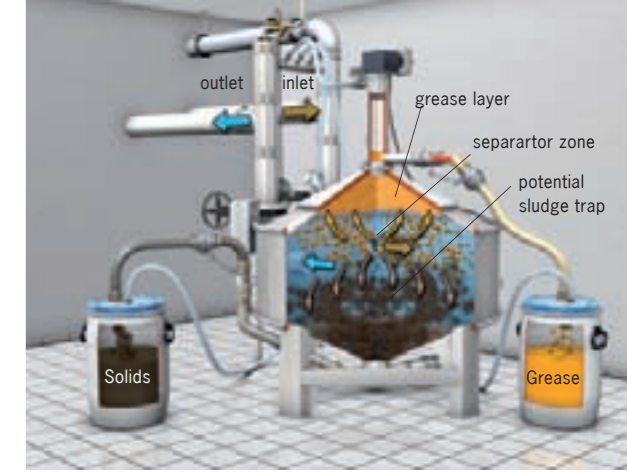

Partial-disposal principle

Further wastewater treatment

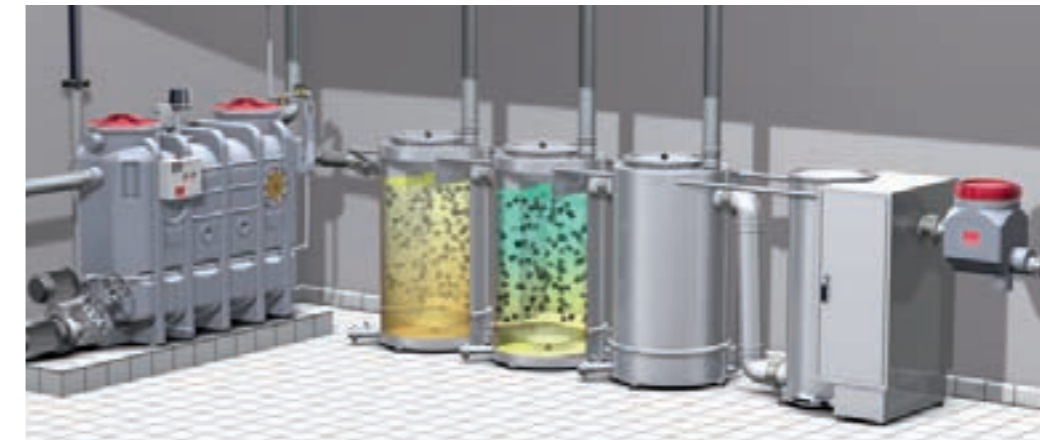

ACO Biojet – the complete modular package for the further treatment of greasy wastewater.

The wastewater discharged by grease separators usually contains a residual amount of lipophilic substances measuring approx. 300 mg/l. If local regulations require more stringent reductions in the amount of lipophilic substances in the discharged wastewater, further treatment becomes necessary.

This is achieved by using ACO high performance filters or ACO BIOJET biological treatment plants, or system combinations incorporating both products. Depending on the product solution, this treatment can further reduce the lipophilic load to a minimum of 80 mg/l. Please contact our project team in Stadtlengsfeld for assistance in dimensioning the required system components.

Product benefits

- odour-tight encapsulation
- no additional breakdown chemicals or consumables required
- low staff and maintenance requirements
- no residues requiring continuous disposal
- segmented design for easy transport of the system components
- contains strains of micro-organisms with no environmental and health risks

Typical applications

- kitchens attached to restaurants, hotels
- canteens

ACO petrol separators in steel reinforced concrete
– compact and inexpensive to maintain



Inflammable or explosive atmospheres can build up in the wastewater piping systems of petrol stations, car washes and vehicle workshops. These hazardous atmospheres must be isolated by separator systems. ACO has four solutions available with the ACO Passavant light-oil separators Oleotop, Oleomax, Oleosafe and Oleopass, which all comply

with EN 858 and German DIN 1999-100. All light-oil separators built by ACO are class I separators (certified with 5 mg per litre residual hydrocarbons). After removal of the coalescence element, they naturally also comply with all specifications for class II separators (certified for 100 mg per litre residual hydrocarbons).

ACO has completely upgraded its light-oil separators in response to the new European standard EN 858. This product line now sets new benchmarks for separator technology.



Oleotop oil separator with sample unit and lifting plant

Typical applications

- Petrol stations, car parks
- Car washes, vehicle washes
- Automotive workshops, automotive trade
- Filling areas, unloading zones
- Petroleum storages, maintenance operations
- Transformer stations, power plants
- Industry and commerce

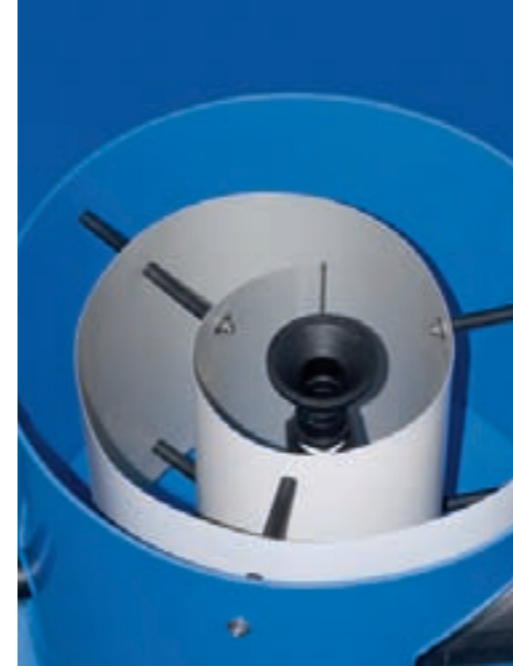

Fast flowing cyclone technology is behind the high efficiency of the new Oleotop separators. The light oils are sucked out through a funnel via an oil ejection device and stored in a closed collecting drum

Oleotop
New filterless class of light-oil separators

Oleotop filterless separators work with the help of Zentri-Duo cyclone technology. The innovation in this separator: sludge and light oils are separated as soon as they enter the separator tank. Whilst the heavy particles are moved centrifugally towards the outside (a) to the edge of the guide walls where they

Featuring low maintenance and high reliability

The filterless coalescence unit is almost maintenance free. No operational shut-downs for cleaning the coalescence unit, thanks to the self-cleaning capacity of the flowing water. Follow-up costs are also slashed because the coalescence unit is non-wearing. The unblockable spiral with a free

ball passage of at least 60 mm prevents blockage of the coalescence unit (e.g. by fine sludge and/or suspended solids) as well as the resulting rise in water level in the separator. These features ensure high levels of operational security. In addition, they also significantly minimise the risk of light oil leaking out of the separator – especially because of insufficient servicing.

settle out, light oil flows simultaneously into the centre (b) – in the centripetal direction – towards the inside walls. This double effect to clean the wastewater reduces the sludge trap volume by 50 per cent – so that the total waste water content is also matchingly low. Oleotop systems are ideal, particularly for washing areas, filling stations or decanting areas.

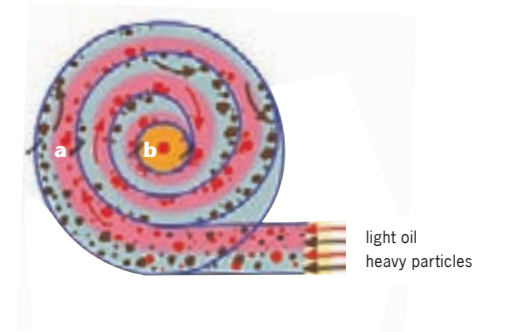

Separators also available in:

- polymer concrete tank
- separate units, sludge trap/separator
- for installation in already existing tanks
- as a free-standing model in stainless steel and PE-HD



Polymer concrete tank with Oleotop separator

ACO backflow preventers in plastic classified in accordance with EN 13564



Previously an occasional hazard, the risk of backflows will undoubtedly increase in future in line with the predicted greater frequency of heavy rain storms. This is because sewers are only designed to cope with average rainfall volumes for economic and technical reasons. Mixed water sewers can therefore very quickly fill up completely during major cloud bursts. It therefore only makes sense to permanently protect all rooms and areas lying below the backflow level from the risk of backflow from public sewers.

Backflow preventers, wastewater raising equipment and pumps from ACO provide effective protection to stop sewage water entering buildings, particularly in rooms below the backflow level. For private, as well as commercial buildings

Cellar gullies with backflow preventers

ACO Junior-K

- telescopic, height-adjustable (30 mm), rotatable (360°) and tiltable (3°) riser with telescopic limit lock
- separate foul-air trap and backflow unit
- easily removable grating with lifting hole
- separate emergency seal
- side inflow with foul-air trap
- in nominal width DN 100

Typical applications

Rooms with gullies below the backflow level such as:

- technical services rooms
- DIY rooms
- laundry rooms
- showers and baths
- floor gullies

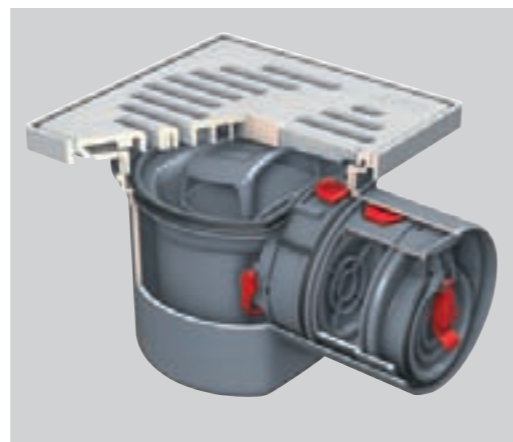

Junior-K in plastic for non-soil wastewater, grey water

ACO Triplex-K-2 double backflow stop for continuous pipe

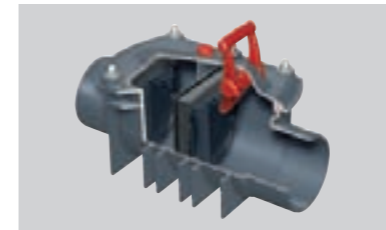

ACO Triplex-K-2 double backflow stop, DN 100 Type 2 pursuant to EN 13564 for installation in unenclosed pipes



ACO Triplex-K-2 double backflow stop, DN 100 Type 2 pursuant to EN 13564 for installation within floor plates

The ACO Triplex-K-2 double backflow stop corresponds to Type 2 EN 13564. This backflow stop is specified for use with wastewater free of faeces. It must only be connected to drainage installations generating wastewater free of faeces, e.g. floor drains, showers or washing machines located below the backflow level. The force of flowing wastewater pushes open the flap in the flow direction to drain the wastewater in the direction of the sewer. If there is backflow, the wastewater backing up from the sewer flows against the normal flow direction and comes into contact with the outer backflow flap. This prevents wastewater from the sewers from flowing back into the building. The second flap is an extra safety feature to ensure that the backflow stop functions even when the first flap fails to close properly

because of the presence of dirt, etc. The ACO Triplex-K-2 also has an emergency seal. This is integrated within the rear flap.

Product benefits

- minimal intrinsic gradient 12 mm, and so optimal for refurbishment
- easily convertible to an automatic backflow stop for wastewater containing faeces

Typical applications

- rooms in single-family houses below the backflow level in which only drainage objects without faeces incidence have to be protected against backflow

ACO Quatrix-K black water automatic backflow stop for continuous pipes

The ACO Quatrix-K black water automatic backflow stop corresponds to Type 3F pursuant to EN 13564. This product is designed for use with wastewater containing faeces. Type 3F backflow stops must be used whenever toilets are installed below the backflow level. When water from the sewers backflows into the pipes, the operating stop is automatically closed by a pneumatic/electric control device. As soon as the wastewater rises up above the permissible height in the pipe, an under pressure sensor sends a signal back to the control unit. The control unit automatically operates the electric motor to close the operating stop. When water no longer backflows into the system, a sensor informs the control unit and the flap is automatically reopened.

The drainage installations connected to the backflow stop must not be used during a backflow situation! The presence

of backflow is signalled by an optical and acoustic alarm. The ACO Quatrix-K also contains a manually operated emergency seal.

Product benefits

- minimal intrinsic gradient 12 mm, and so optimal for refurbishment
- height adjustable top section for perfect adaptation to floor level
- optional step-wise height adjustable sealing flange for flexible adaptation to the sealing level
- pneumatic sensor for problem-free operation

Typical applications

- rooms in single-family houses below the backflow level in which, among others, a urinal or a toilet have to be protected against backflow



ACO Quatrix-K black water automatic backflow stop, DN 100 Type 3F pursuant to EN 13564 for installation in unenclosed drainpipes.



ACO Quatrix-K black water automatic backflow stop, DN 100 Type 3F pursuant to EN 13564 for installation in floor plates.

ACO wastewater lifting plants and submersible pumps – a complete range for professionals



Professional back-flow preventers are one of the main areas of ACO product excellence in its building drainage product line. ACO has a complete range of intelligent solutions with gullies and backflow preventers, as well as lifting plants and pumps.

ACO wastewater and soil raising units

Muli-Star lifting plants are designed to raise wastewater from deeper lying rooms such as conveniences, cloak-rooms, showers or complete bathrooms. Also available with a redundant unit for higher operating reliability in housing blocks or small offices.

- optimum tank volume utilisation – less hysteresis and pump wear
- Microprocessor-controlled switchbox – simple operation
- Low-noise pumps and back-flow preventers – quiet, better living and working conditions
- Special connection piece for rapid assembly to vacuum pipe system

The **Muli-Pro** units are mainly used in public and commercial buildings e.g. office buildings, schools, hotels and factories.

- high-quality tank in stainless steel grade 316 or polyethylene
- designed for wastewater containing grease and soil behind a separator
- free diameter up to 100 mm
- variable by up to four variable inflow connection options
- wide scope for positioning in the installation space
- PE tanks also connectable in series
- raising equipment with PE tanks, also available as a separate pump unit

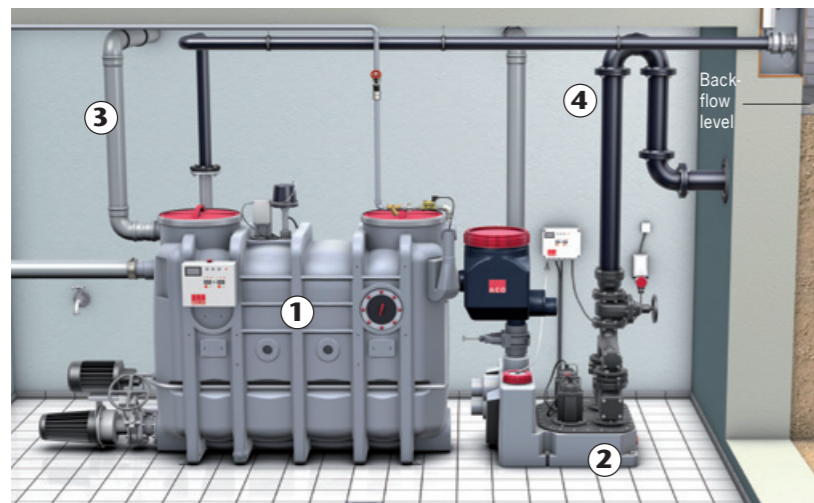

"Grease separators whose normal water level is beneath the back-flow level (cf. EN 752-1) must be drained by a downstream raising unit."
Quote from EN 1825-2, Section 7.3

Lifting plants/pumping stations for grease separators

- 1 grease separator
- 2 lifting plant
- 3 ventilation pipe
- 4 backflow loop

Muli-Max F complete pumping station for non-soil wastewater and soil

Muli-Max F complete pumping station for non-soil and soil wastewater. This complete pumping station is mainly used for draining surfaces and deeper lying areas in private and commercial buildings. The complete pumping station ensures optimal vacuum pump drainage of domestic wastewater. The Muli-Max F complete pumping station is equipped with one or two pumps (SITA or SAT models).

- float-resistant PE container
- also available in steel reinforced concrete
- encrustation-resistant collecting tank
- low maintenance and flexible over-fill pressure switch
- installation depth up to 3000 mm



Muli-Max F pumping station

ACO Sinkamat-K mini lifting plant

The ACO Sinkamat-K mini lifting plant is an innovative solution for draining rooms lying below the backflow level. It is particularly suitable for drainage installations in cellars such as showers, washing machines or sinks for which no fitted drainage was originally planned. This product is used for draining wastewater free of faeces. The ACO Sinkamat-K mini lifting plant also provides optimal protection against backflow because the pressure pipe has to be led above the back-flow level.

- compact Dimensions
- high quality polyethylenetouch
- available in two types
 - For burries installation
 - For above-floor installation
- installation without tools



Pumps



SAT pump, with liquidising system (right) of the SITA submersible pump series

The SAT submersible pumps for clean and dirty water are suitable for stationary and transportable applications. They are designed to pump mildly contaminated water and rainwater, empty swimming pools, and drain collecting sumps and small cellar sumps.

The SITA wastewater and soil submersible pump is used to pump domestic sewage containing soil. Pump range designed for private, industrial and communal applications like abattoirs, food conservation factories and vacuum sewer systems.



SITA submersible pump. The laterally inset vortex wheel (right) guarantees complete diameter flow. It is therefore also suitable for fibrous and contaminated wastewater

ACO wastewater treatment technology



In face of declining drinking water reserves and increasing unit costs, ACO has focused its attention on the recycling of wastewater for re-use. ACO systems use aeration, filtration and biological purification methods.

ACO Maripur – the highest standards of wastewater treatment

The ACO Maripur system purifies water by biological wastewater treatment combined with submerged negative pressure micro-filtration membrane technology to filter out activated sludge, bacteria and viruses.

With no need for any final purification, ACO Maripur technology purifies water in compliance with numerous quality standards: IMO/MARPOL, HELCOM, German Federal Law Gazette No. II, Page 1378 and No. I, page 1221, USCG, US Federal

Law Gazette No. 40, Section 133, ADNOC Australia and Australian Federal Environmental Agency requirements as Alaska Agreement. ACO Maripur was developed as a modular system with four basic sizes for purifying wastewater generated by 25, 50, 100 and 200 people. We can also produce customised solutions upon request.

The bioreactor is in stainless steel AISI 316Ti as standard. Construction in other materials is also possible upon request.

Typical application

- superyachts and Megayachts
- military ships
- ferries
- river cruises
- special ships
- offshore

Benefits

- low operating costs
- smaller dimensions and more compact than conventional solutions
- insensitive to movement on board ship
- options for purifying black and grey water, or black water only
- suitable for gravity and vacuum sewage systems
- easy installation and commissioning
- automatic operation, easy maintenance



ACO Clara – For the treatment of wastewater from single-family households and small business units

ACO Clara sewage treatment plants are designed for the complete biological purification of domestic waste water.

Typical application

- single-houses
- residential areas
- hotels
- boarding-houses
- companies, etc.

Treatment process

- mechanical pre-treatment
- biological treatment by activated sludge
- final gravity sedimentation

ACO Clara sewage treatment plants comply with all the requirements of EN 12566-3, which is proven by a CE certificate.

Benefits

- perfect statics
- easy installation with no additional concreting
- very stable and high treatment efficiency during irregular hydraulic and biological loads – overload-resistant
- first-class electrical components
- effective purification
- low maintenance
- low energy consumption
- odour-proof access cover with smart construction
- high volume of storage tank

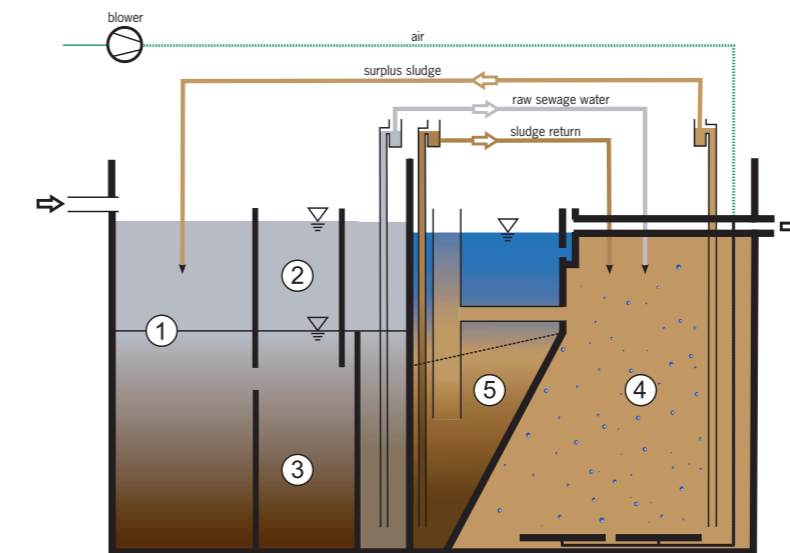

The ACO Clara sewage treatment plant consists of a mechanical pre-treatment part and a biological compartment. The mechanical pre-treatment part is formed of a sedimentation tank with a high buffer area volume and the biological part consists of an activation tank and a built-in final sedimentation tank. Surplus sludge is stored in the storage area, which in fully loaded plants is capable of holding about 100 - 150 days' capacity.

Key

1. pre-treatment
2. buffer area
3. storage area
4. activation tank
5. final sedimentation tank

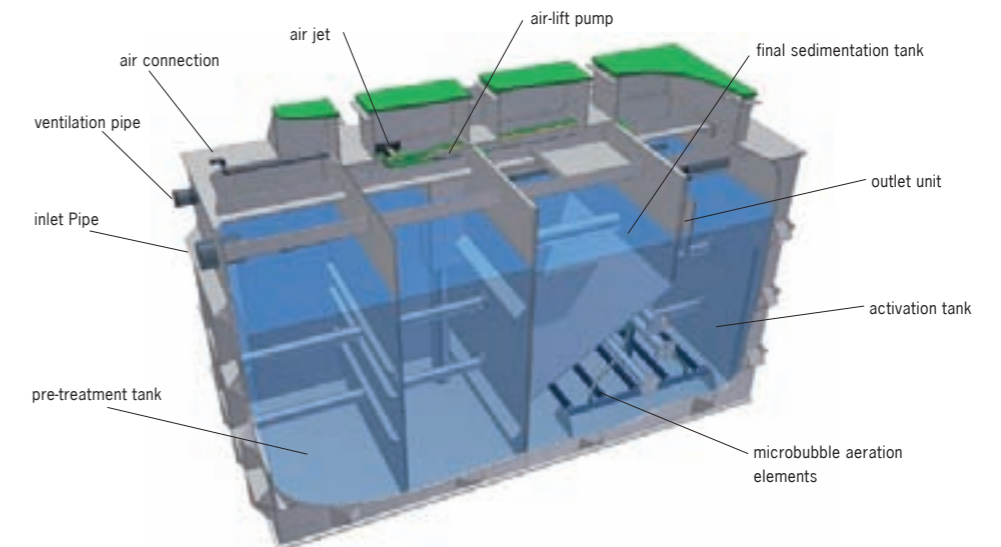

ACO references

ACO products provide you with reliable drainage wherever they are used. Versatility and quality of ACO products will solve the most mundane problems of every day life, as well as the challenges of major projects.



Central Fish Market, Kuwait



Formula 1 circuit, Shanghai



Innovation Prize Award
GaLaBau 2000



Airport, Frankfurt



Olympic Stadium, Beijing



Hotel Burj Al Arab, Dubai



Olympic Boulevard, Sydney



CCTV (China Central Television) New Tower, Beijing



Westminster Cathedral, London



reddot design award
winner 2009

The curved model of the unilluminated ACO ShowerDrain won the reddot design award 2009

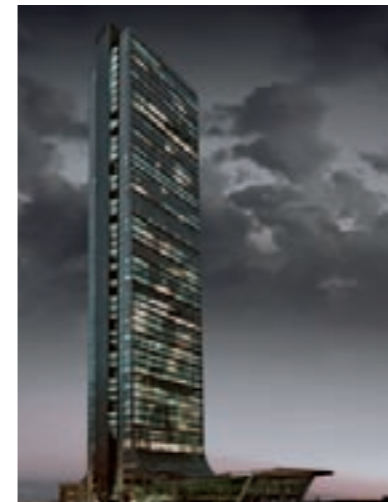

Sapphire Tower, Istanbul



The curved model of the unilluminated ACO ShowerDrain won the iF product design award 2009



Olympic Stadium, London



Petronas Towers, Kuala Lumpur, Malaysia



Schleswig-Holstein Design Award
2001/2002 und 2003/2004



Atomium, Belgium

Marco Polo Tower, Hamburg



Potsdam Place, Berlin



The ACO Group Companies worldwide

Holding

ACO Severin Ahlmann
GmbH & Co. KG
Rendsburg/Büdelisdorf

Albania

ACO Elemente Ndërtimi shpk
Tirana

Australia

ACO Polycrete Pty Ltd
Emu Plains, Sydney
Adeleide
Brisbane
Melbourne
Perth

Austria

ACO GmbH
Baden

Belgium

ACO Passavant NV/SA
Merchtem

Bosnia and Herzegovina

ACO d.o.o.
Sarajevo

Bulgaria

ACO Building Elements EOOD
Sofia

Brazil

ACO Soluções em
Drenagem Ltda.
São Paulo

Canada

ACO Systems Ltd.
Mississauga, Ontario

China

ACO Drainage Technology
(Shanghai)
Co. Ltd.
Shanghai
Beijing
Guangzhou

Croatia

ACO Gradevinski elementi d.o.o.
Zagreb

Czech Republic

ACO Industries k.s.
Příbryslav

ACO Stavební prvky spol. s.r.o.
Jihlava

ACO Marine s.r.o.
Prague

ACO Industries Tabor s.r.o.
Sezimovo Ústí

Denmark

ACO Nordic A/S
Ringsted

ACO Plastmo A/S
Ringsted

ACO Funki A/S
Herning

Hvidbjerg Vinduet A/S
Hvidbjerg/Thyholm

Isolar Hvidbjerg Thy A/S
Hvidbjerg/Thyholm

Estonia

ACO Nordic OÜ
Tallinn

Finland

ACO Nordic Oy
Turku

France

ACO Produits Polymères S.A.
Notre Dame de l'Isle

Germany

ACO Severin Ahlmann
GmbH & Co. KG
Rendsburg/Büdelisdorf
Reith

ACO Tiefbau Vertrieb GmbH
Rendsburg/Büdelisdorf

ACO Hochbau Vertrieb GmbH
Rendsburg/Büdelisdorf

ACO Selbstbau Vertrieb GmbH
Rendsburg/Büdelisdorf

ACO Passavant GmbH
Philippsthal
Stadtlengsfeld

ACO Beton GmbH
Bürstadt
Stockstadt

ACO Guss GmbH
Kaiserslautern
Michelbacher Hütte, Aarbergen

ACO Eurobar GmbH
Kaiserslautern

ACO Edelstahl GmbH
Philippsthal

ACO Funki GmbH
Rendsburg/Büdelisdorf

Inotec Sportanlagen-
und Edelstahltechnik GmbH
Rendsburg/Büdelisdorf

Greece

ACO Building Quality Solutions
SA
Athens

Hungary

ACO Magyarország Bt.
Budapest

India

ACO Systems and Solutions
Pvt.Ltd.
Bangalore

Italy

ACO Passavant SPA
Osteria Grande, Bologna

Latvia

ACO Nordic SIA
Riga

Lithuania

ACO Nordic UAB
Vilnius

Malaysia

ACO Polycrete Pty Ltd
Kuala Lumpur

Mexico

ACO Espacios de la
Construcción, S.A. de C.V.
Naucalpan

Netherlands, The

ACO B. V.
Doetinchem

New Zealand

ACO Polycrete Pty Ltd
Auckland
Christchurch

Norway

ACO Nordic AS
Slemmestad

Poland

ACO Elementy Budowlane
Sp.z o.o.
Warsaw, Legionowo

Plastmo Polska Sp. z o.o.
Warsaw, Janki

ACO Funki Sp. z o.o.
Gorzno

Portugal

Lusitana ACO
Elementos de Construção,
Unipessoal Lda.
Matosinhos
Lisbon

Romania

ACO SRL
Afumati

Russia

ACO Ltd.
Moscow

Serbia

ACO gradjevinski elementi d.o.o.
Belgrade

Slovakia

ACO Stavebné prvky, s.r.o.
Bratislava

Slovenia

ACO gradbeni elementi,
zastopanje, d.o.o.
Šmarje pri Jelsäh

Spain

ACO Productos Polímeros, S.A.
Maçanet de la Selva

Sweden

ACO Nordic AB
Göteborg

Switzerland

ACO Passavant AG
Netstal, GL
Bätterkinden, BE

Turkey

ACO Yapi Malzemeleri Sanayi
ve Ticaret Ltd. Sti
Istanbul

Ukraine

ACO Building Elements Ltd.
Kiev
Lviv

United Arab Emirates

ACO Systems FZE
Dubai

United Kingdom

ACO Technologies plc
Shefford

ACO Building Drainage
Bedford

USA

ACO Polymer Products, Inc.
Casa Grande, AZ
Chardon, OH .
Charlotte, NC

ACO Yankee Plastic, Inc.
Riverdale, IA

ACO complements the core drainage

competence with which it became

*world leader with intelligent con-
struction components for buildings.*

From cellars to roofs, light shafts,

window systems, drain mats,

domed roof-lights and light panels

ACO deliver economical system

solutions for private and commer-

cial buildings.



The Agricultural division of ACO

is specialized in the development,

production and sales of compo-

nents and systems for pig produc-

tion. It covers all product areas

within housing mechanization,



pen equipment and feeding. The

products improve the production

results and are developed to take

care of animal welfare, the environ-

ment and a user friendly design.



**ACO Severin Ahlmann
GmbH & Co. KG**

P. O. Box 320, 24755 Rendsburg
Am Ahlmannkai, 24782 Büdelsdorf
Germany
Phone +49 4331 354-172
Fax +49 4331 354-222
info@aco-international.com
www.aco.com